

# HARDWARE MANUAL

## LPG Engine kit

# VGI



# Vogels

## Autogas Systems

**Vogels Autogas Systems**

Ekkersrijt 3016, 5692 CA Son, The Netherlands

Email: [info@vogelsautogas.nl](mailto:info@vogelsautogas.nl)

Online: [www.vogelsautogas.com](http://www.vogelsautogas.com)

**INDEX:**

<b>SUBJECT</b>	<b>Page</b>
- SYSTEM DESCRIPTION AND INSTALLATION .....	3
- Introduction .....	3
- Inlet and outlet signals .....	4
- Components survey .....	5
- General conditionals before the installation .....	6
- Gas hoses survey .....	7
- Pressure regulators .....	8
▪ Pressure Regulator Landi LI02 .....	8
▪ Pressure Regulator Landi LI10 .....	9
▪ Pressure regulator Landi IG1 .....	10
▪ Pressure Regulator Emer Palladio .....	11
- Pressure regulator installation instructions .....	12
- Gas filter-unit .....	13
- Injector rail AEBINJ .....	14
- Injector rail Valtek Type 34 .....	15
- Injectorrail installation instructions .....	16
- Nozzles .....	17
- Water temperature sensor .....	18
- Pressure- MAP-sensor AEB025 .....	19
- Gas-ECU .....	21
▪ ECU VGI 4 Cyl. AEB MP48 (OBD) .....	22
▪ ECU VGI 4 Cyl. AEB2001NC OBD .....	25
▪ ECU VGI 8 Cyl. AEB2568D OBD .....	28
- GAS ECU Installation Instructions .....	31
- Electrical Installation Instructions .....	32
▪ Fuse Installation Instructions .....	32
▪ Engine Speed Signal Installation Instructions .....	32
▪ Connection to the AEB025 Sensor .....	33
▪ Lambda Signal connection .....	33
▪ Tank wire connections .....	33
▪ Injection Signal Cutting Installation Instructions .....	34
▪ OBD Connections .....	38
- Userinterface / Gas Switch .....	40
- Maintenance and service .....	41



## **SYSTEM DESCRIPTION AND INSTALLATION:**

### **Introduction**

The VGI gas system is one of the most modern auto gas systems momentarily available in the market. It concerns as the name already indicates a sequential slave injection system, which means that for each cylinder the right amount of gas is being injected.

The system uses the petrol-injector signals as main inlet signal to determine the right amount of gas to be injected for each cylinder of the engine on that particular moment.

The system normally starts on petrol and when the engine is warm enough, the fuel switch in gas mode, the gas ECU (Electronic Control Unit) will pick the right moment to switch over to gas.

As first the solenoids on the tank and pressure regulator will open, so LPG can enter the pressure regulator. The pressure will be regulated at approximately 1 bar overpressure for the rest of the gas injection system. The gas flows from the pressure regulator through a dry gas filter the injector rail to feed each single gas injector. The gas filter will block particulars and avoid them polluting the gas injectors. From the switch-over moment (petrol to gas) the petrol injector signals will be interrupted by the gas-ECU and routed to its micro processor to calculate the gas injection signals.

Using the petrol injection signal to determine the gas injection signal is called the slave system principle. Moreover the VGI system works according the "same cylinder" principle, which means that the gas injection signal is based upon the petrol injection signal of the very same cylinder and rotation of the engine. So no delay which can cause any control frequency degreasing will occur. So is the gas injection signal for cylindernr. 1 based upon the petrol injection signal of petrol injectornr. 1 of that very same moment. Each gas injector will inject the same amount of gas in fuel quantity as it would do on petrol.

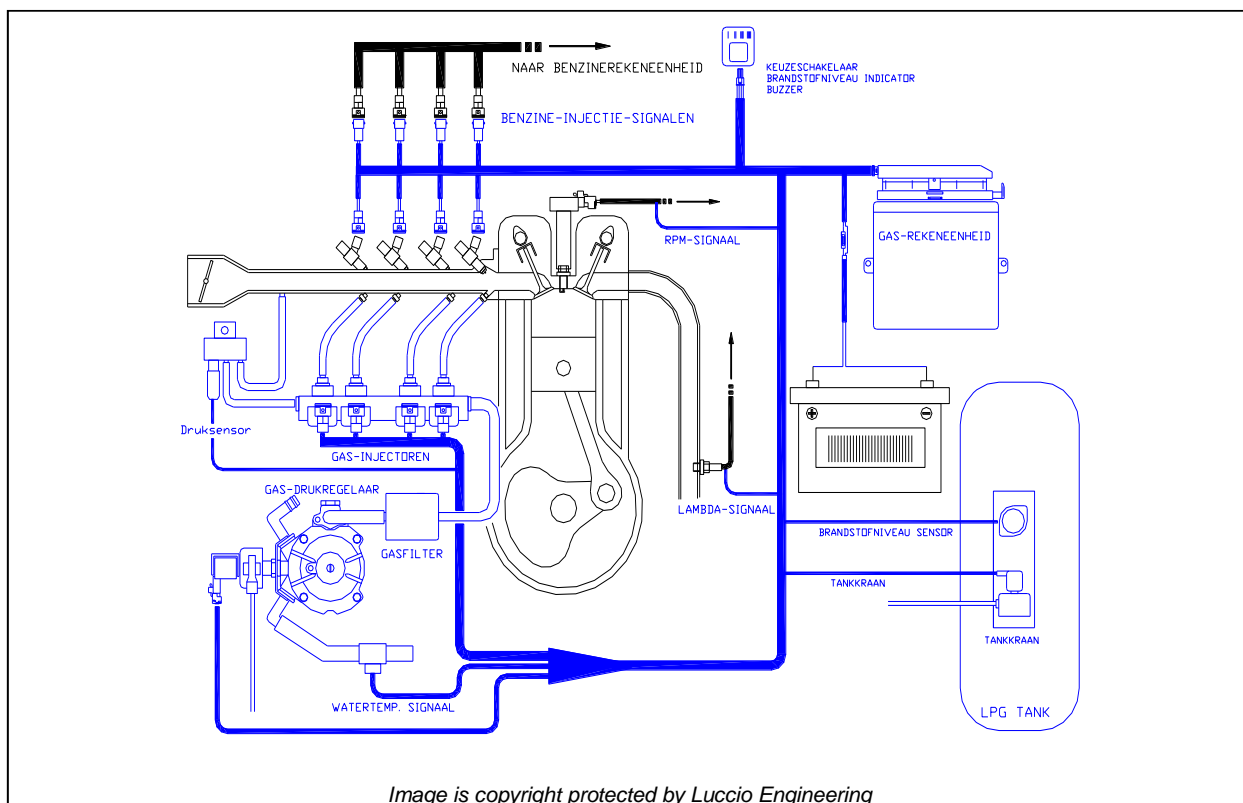

Petrol and LPG are two very different fuels and have totally different properties which need to be taken in consideration for the "translation" of the petrol to gas injection signal. In transient conditions and during the warming up phase, compensation strategies need to be activated to correct the differences between the two fuels. To be able to effectuate these compensation strategies, the system uses other inlet signals such as gas temperature, gas pressure and water temperature. Besides the driving of the gas injectors the gas ECU has also other functions, such as measuring and indicating the fuel level, driving the solenoids on the tank and pressure regulator and switch over from one fuel to another. When the car has run out of LPG the system automatically switches back to petrol and warns the driver with an acoustic sound.

During the installation and maintenance of the system it is possible to check its functioning and check its diagnostics with the interface loom and interface software installed on a laptop or other PC.



**Inlet and outlet signals:**

Inlet signals

Inlet signal	Function
Petrol-injection signals	The system uses as main inlet signal the petrol injection signals of each separate petrol injector to determine the gas injector signal. The VGI system is a “slave system” and follows the petrol injector signals to translate this signal to a gas injection signal. The power supply of the petrol injectors is used as an ignition signal for the gas-ECU.
RPM signal	The RPM signal (engine speed) is used as a reference parameter to be able to translate the petrol injection signal to the gas injection signal. Moreover the signal is used to determine whether the engine is still running.
Water temperature signal	The water temperature is used as a condition for switch over from petrol to gas. Moreover it's being used for the correction of the fuel differences in cold engine conditions. The temperature signal can be taken from a temperature sensor that is to be placed in a water hose or from the original engine temperature sensor.
Gas pressure signal	By an increasing absolute gas pressure the density of the gas will increase as well and so will the energy value per volume unit. To compensate this variation, a gas pressure correction strategy is introduced to shorten in this case the injection duration. A very low gas pressure will make the system switch back to petrol.
Gas temperature signal	An increasing gas temperature will lead to a lower gas density. To compensate this variation, a gas temperature correction strategy is introduced to increase in this case the injection duration.
Fuel level signal	The fuel level sensor gives the gas ECU an indication of the remaining fuel in the tank. The gas ECU displays the fuel level on the fuel switch.
MAP signal	The manifold absolute pressure signal can be used as an option to determine the pressure difference between the inlet and outlet of the gas injectors.
Lambda signal	As an option the lambda signal can be connected to the gas ECU to display its value in the interface software. This can be beneficial during the calibration of the vehicle.

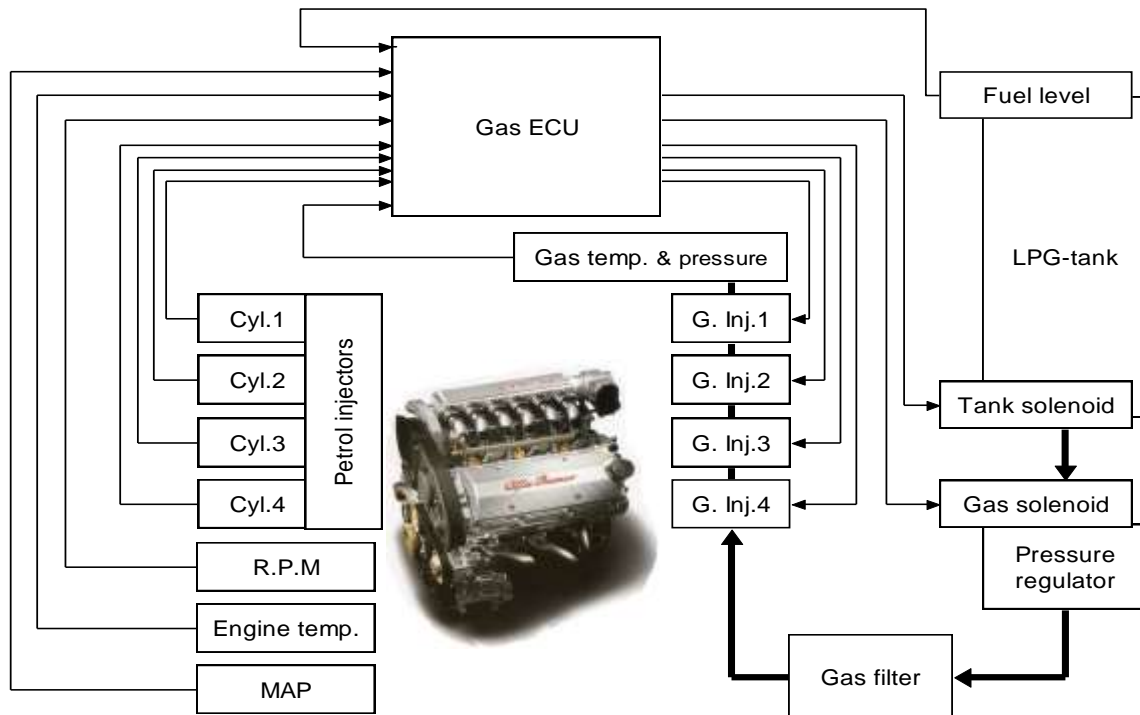



### Outlet signals

Outlet signal	Function
Gas-injectionsignal	The main outlet signals are gas injector signals which determine the amount of injected fuel into the engine. Each cylinder has its own injector and signal. Petrol injection signal of cylinder A corresponds with gas injector A.
Tank solenoid signal	This signal opens or closes the solenoid valve on the outlet of the LPG tank, so LPG can or cannot run to the pressure regulator.
Gas solenoid valve	This signal opens or closes the solenoid valve on the inlet of pressure regulator, so LPG can or cannot run into the pressure regulator and the rest of the system.
Serial communication with the fuel switch.	The fuel switch and Gas ECU are connected with each other through a serial communication link. They inform each other on fule selection, fuel level and possible diagnostics errors.
Serial communication with a PC.	Using an interface cable and an interface program on the PC or laptop it is possible to check the system and modify settings. The gas ECU and PC communicate trough a serial connection.

### Components survey

- 1 Fuel switch / User interface
- 2 Gas ECU (Electronic Control Unit)
- 3 Dry gas filter
- 4 Pressure regulator
- 5 Gas injector rail with pressure and temperature sensor

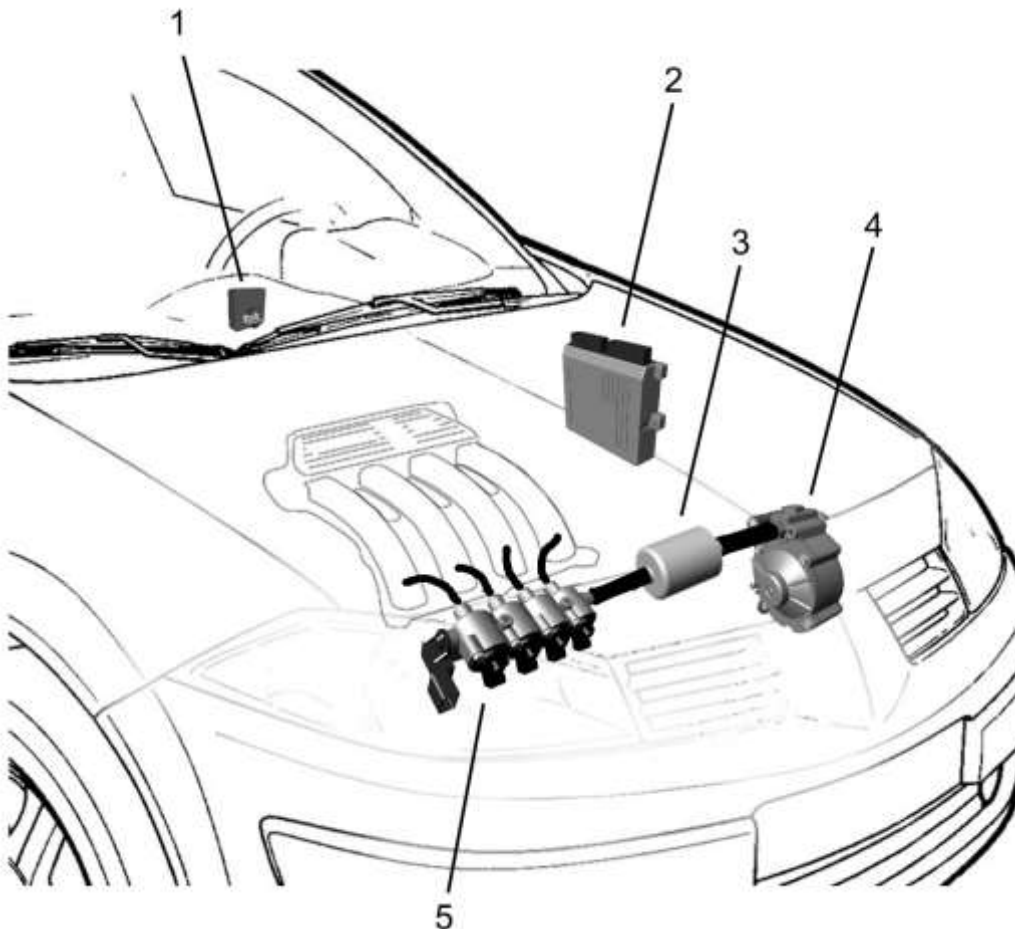

Image is copyright protected by Luccio Engineering



## **General conditionals before the installation**

### Before the conversion

Check before you start with any conversion if there are any malfunctions or diagnostics in the vehicle on petrol. This can avoid many problems after the conversion.

Moreover check the vehicle on the following points:

- The state of the engine air inlet filter.
- The state of the ignition system such as spark plugs, spark plug cables, coils.
- Inlet and outlet valves for leakage and check the valves clearance.
- Functioning of the lambda probe and the catalyst.

When necessary first make the proper adjustments on petrol and replace broken parts before converting the vehicle to gas.

The following types of vehicles can NOT be converted with the VGI system

- With engine with a carburettor
- Bosch K-jetronic injection
- Direct injection engines (Use a special version of VGI)

### Remarks regarding all gas containing components

- Fix all components in the engine compartment according to the specific installation manual of that particular vehicle. Fix the components using the brackets coming with the kit on to solid parts of the vehicle or directly on to these solid parts.
- Never fix a gas component in or close to space of the ventilation system of the passenger compartment.
- Never fix any component closer than 200 mm away from a heat source such as the exhaust system for example. In any case this unavoidable, place a heat shield of minimum 1 mm thick in between.
- Avoid hoses and tubes to make sharp bends or to fold.

### Remarks regarding all components

Add a protective anti corrosion layer to all metal components such as the regulator and brackets and all fixing points after the complete installation and check-up of the system. Do this to avoid rust and corrosion and a good conservation of the system and vehicle.

Fix all components according to European and or national regulations.



### **Gas hoses survey:**

The pictures below give a schematic view of how the (gas) hoses are connected to the various gas components and therefore how these components are connected to one another.

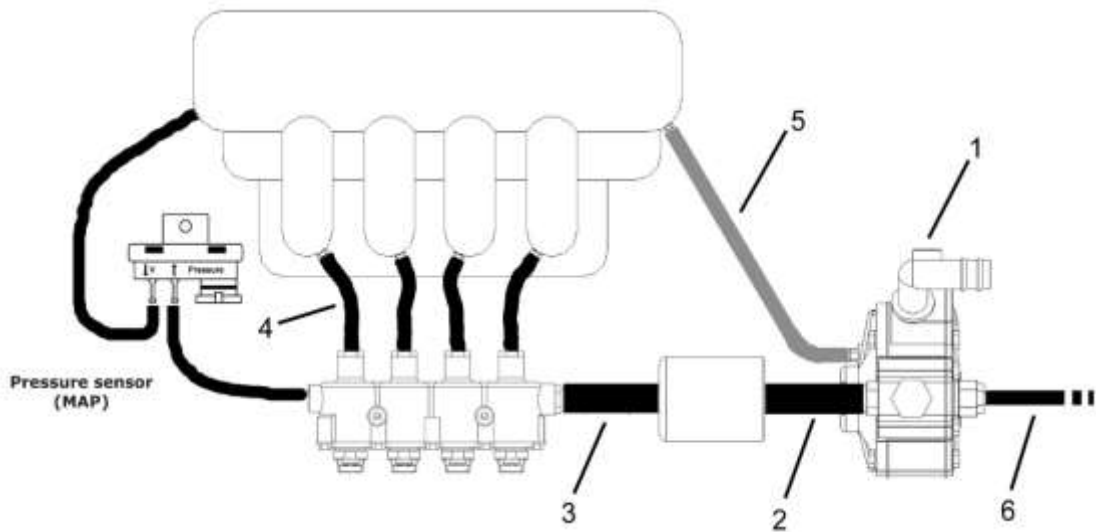

*Images are copyright protected by Luccio Engineering*

#### **Legenda:**

1. LPG-inlet
2. 14 mm hose between pressure regulator and gasfilter.
3. 14 mm hose between gasfilter and injector rail.
4. 6 mm hose between injector rail and nozzle in inlet manifold.
5. MAP-connection
6. Overpressure connection. The hose has to finish outside of the engine compartment (R-67-01)

#### **Gas hose installation instructions:**

- Avoid gas hoses to run closely to heat sources.
- Avoid gas hoses to run past sharp objects and possibly be damaged in time.
- Connect the gas hoses correctly to the components and avoid and check for leakages.





**Pressure regulators**

The VGI gas system is available with different types of pressure regulators. The choice depends on the power of the engine and the budget of the installation.

- Landi LI02
- Landi LI10
- Landi IG1
- Emer Palladio

The available pressure regulators are described below:

**Pressure Regulator Landi LI02**

The pressure regulator is a single-stage, compensated, diaphragm type, with water-gas heat exchanger, It is calibrated for a supply pressure of: - 0.95 bar (95 kPa), higher than the pressure present in the inlet manifold for normally-aspirated vehicles.

**Technical specifications LI02:**

Weight 840 g.  
 Working pressure:..... 0.95 bar (95 kPa) rel.  
 Nominal operating flow rate:..... 30 Kg/h / 100kW  
 Working temperature:..... -20 to 120 °C  
 Safety valve calibration pressure:.. 3.5 bar (350 kPa)  
 Type approval R67:..... E 13 67R-010056

**Shut-off valve specifications:**

Type:.....MED Type 71  
 Coil tension:.....12V DC  
 Power of coil:.....11W  
 Normally:.....Closed  
 Homologation LPG No.:E4 67R-0193001

**Legend:**

- 1) LPG-input and connection with shut-off valve.
- 2) LPG-outlet
- 3) Pressure adjustment
- 4) Engine vacuum (MAP)
- 5) Overpressure valve
- 6) Water in- and outlet
- 7) Fixing point

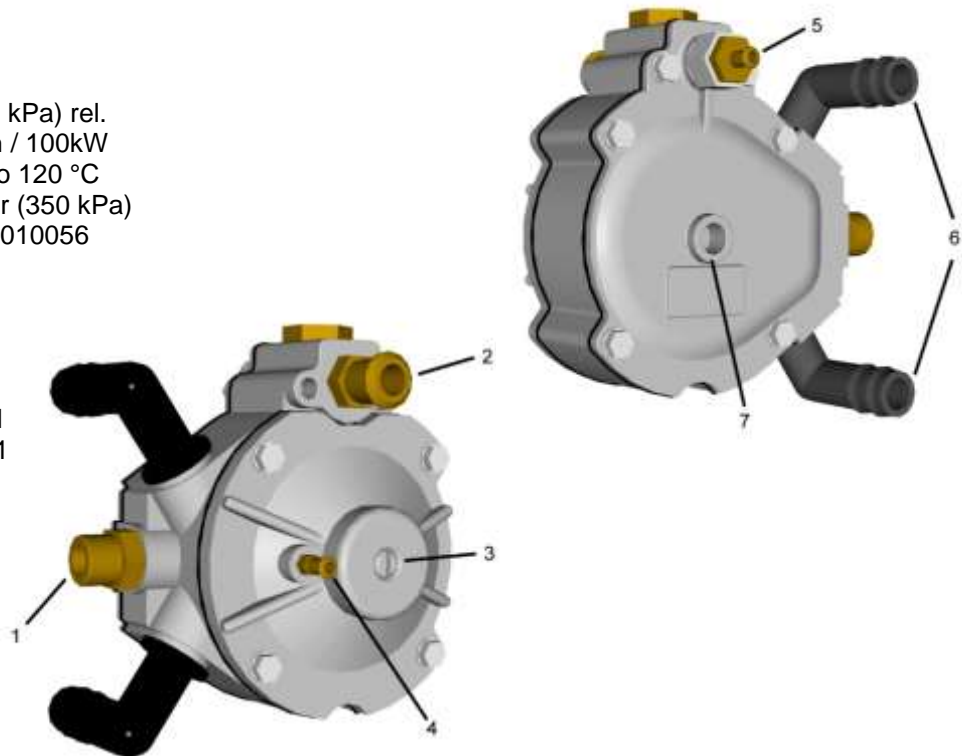

- A: Pressure Regulator
- B: Filter-unit
- C: Injector rail
- D: Nozzles
- E: MAP-connection
- F: Inlet manifold
- G: Gas inlet
- H: Gas Tube 14mm
- I: Gas Tube 14mm
- L: Gas Tube 6mm
- M: MAP Tube
- N: Water heating tubes

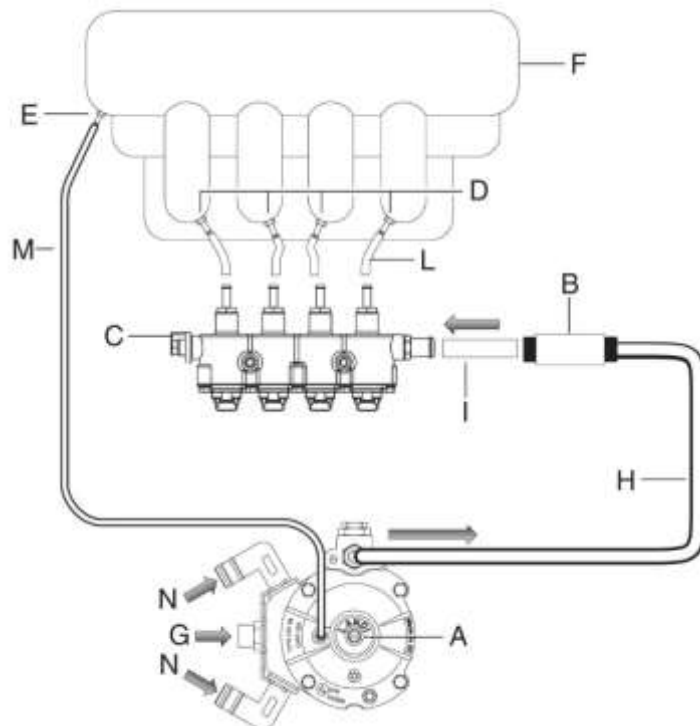





### Pressure Regulator Landi LI10

The pressure regulator is a single-stage, compensated, diaphragm type, with water-gas heat exchanger, It is calibrated for a supply pressure of: - 0.95 bar (95 kPa), higher than the pressure present in the inlet manifold for normally-aspirated vehicles.

#### Technical specifications Li10:

- Weight 1310 g.
- Working pressure:..... 0.95 bar (95 kPa) rel.
- Nominal operating flow rate:..... 40 Kg/h / 140kW
- Working temperature:..... -20 to 120 °C
- Safety valve calibration pressure:.. 3.5 bar (350 kPa)
- Type approval R67:..... E 13 67R-010056

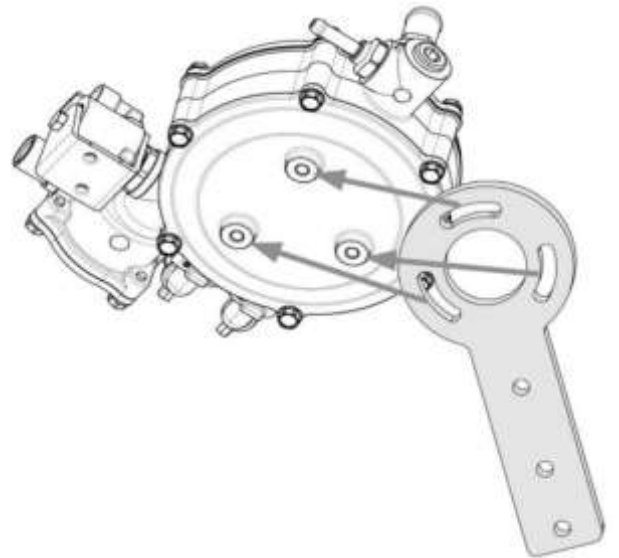
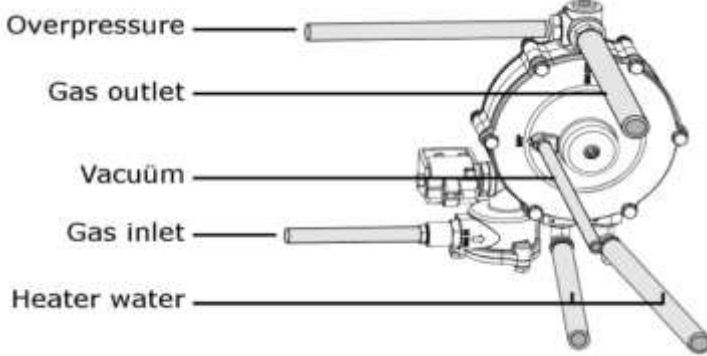

OK

NOT OK





**Pressure regulator Landi IG1**

The IG1 pressure regulator is a two-stage type. It is heated with engine heat by the engine coolant. The integrated valve (1 to 3) also filters incoming gas. The pressure regulator adjusts the output pressure to just 1.0 bar (100 kPa) above the pressure at the compensation port (6) (MAP). The first stage has an operating pressure of 1.6 bar above atmospheric pressure. The second stage ensures further pressure reduction and is adjustable.

**Specifications:**

First stage operating pressure: 1.6 bar (160 kPa) relative  
 Second stage operating pressure: 1.0 bar (100 kPa) rel.  
 Nominal flow volume: 40 Nm<sup>3</sup>/h  
 Working temperature: -20 to 120 °C  
 Pressure relief flow valve: 4.5 bar (450 kPa)  
 Homologation LPG No.: E13 67R-010025

**Shut-off valve specifications:**

Type: MED Type 71  
 Coil tension: 12V DC  
 Power of coil: 11W  
 Normally: Closed  
 Homologation LPG No.: E4 67R-0193001

The IG1 pressure reducer is available in 3 versions:

- IG1 Normal:** until engine power of 160 kW.
- IG1 Maggiorato:** until engine power of 200 kW
- IG1 Super Maggiorato:** until engine power of 280 kW

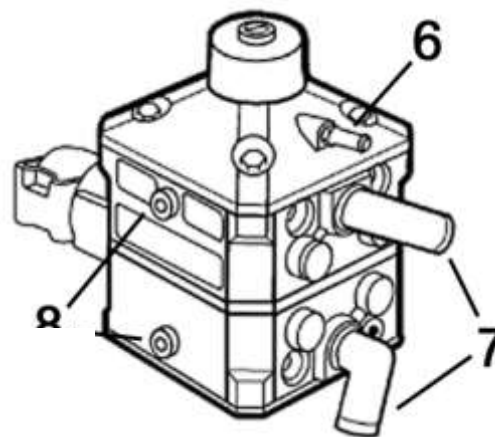
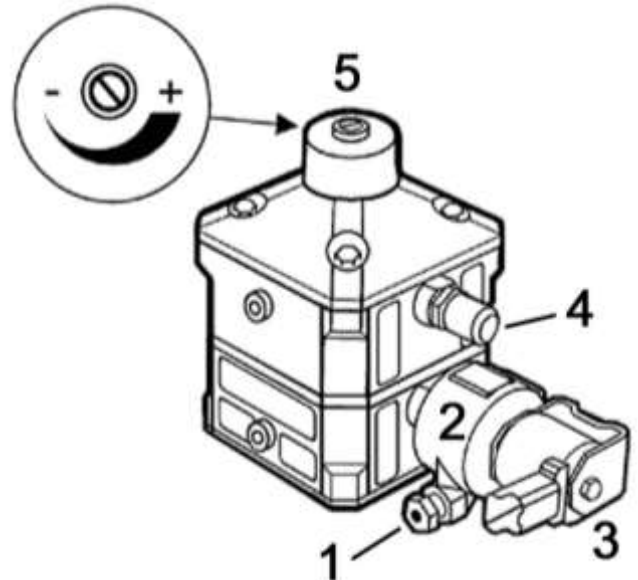

**Legend:**

- 1) LPG inlet port
- 2) Filter
- 3) LPG flow valve
- 4) LPG outlet port
- 5) Second stage pressure adjustment
- 6) MAP connection
- 7) Water inlet and outlet port
- 8) Fixing points

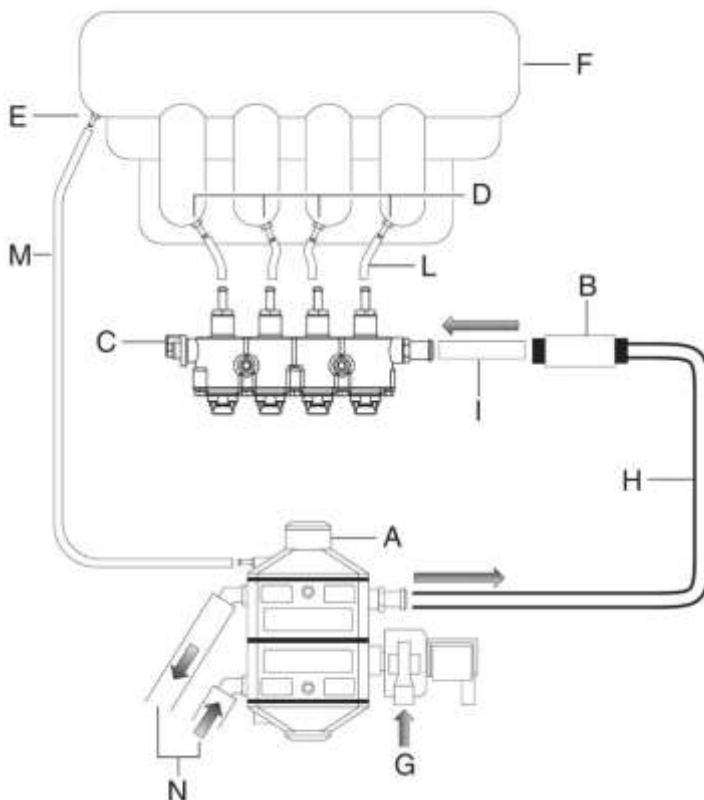

- A: Pressure Regulator
- B: Filter-unit
- C: Injector rail
- D: Nozzles
- E: MAP-connection
- F: Inlet manifold
- G: Gas inlet
- H: Gas Tube 14mm
- I: Gas Tube 14mm
- L: Gas Tube 6mm
- M: MAP Tube
- N: Water heating tubes



**Pressure Regulator Emer Palladio:**

The vaporizer, as its name indicates, is a device which has two principal functions:  
 regulate the feed pressure of LPG tank, to the service pressure;  
 and convert the LPG from liquid state to gaseous state. This device has two independents contiguous chambers. In first chamber the pressure is regulated and LPG is gasified (entering in liquid state). Second chamber makes the interchanger of heat function.  
 The maximum LPG feeding pressure, in liquid state, to reducer is 3.000 Kpa (30 bar).

In regulation chamber, pressure is reduced to 140 Kpa (1,4 bar) relative, by a regulation device formed by a spring and the diaphragm, that is hooked to the closing valve direct plunger.  
 Also, when is gasified, the gas which is in the chamber is 100% gaseous state, that is which comes out through the hose toward the injectors rail.

**Specifications:**

- Nominal operating pressure:... 1.4 bar (140 kPa) relative
- Adjustable operating pressure:.....0.9 – 1.6 bar relative
- Nominal flow volume:..... 50 Nm3/h
- Working temperature:..... -20 to 120 °C
- Pressure relief flow valve:..... 4.5 bar (450 kPa)
- Intergrated temp. sensor:.....NTC 4,7 kΩ
- Homologation LPG No.:..... E4 67R-010218

**Shut off valve specifications:**

- Type:.....Valtef 07 BFC
- Coil tension:.....12V DC
- Power of coil:.....11W
- Normally:.....Closed
- Homologation LPG No.:...E4 67R-010041

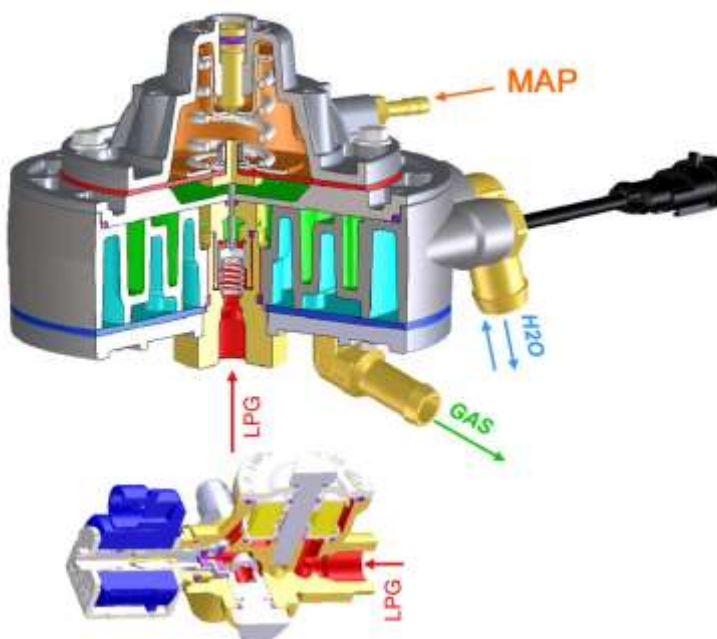
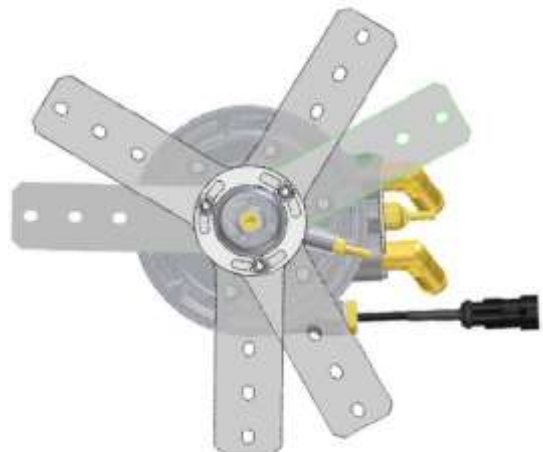



## **Pressure regulator installation instructions:**

The following rules relate specifically to the installation of the pressure regulator:

- Install the regulator in such a way that it is accessible for maintenance and adjustment purposes.
- Never install the pressure regulator directly on the engine or on components located on the engine.
- Install the pressure regulator with the adjustment side at the top, unless otherwise specified in the installation manual.
- Remove ALL plastic protection plugs from the pressure regulator.
- Connect the coolant hoses as indicated. The coolant nipples on the pressure regulator can be turned to ensure proper routing of the coolant hoses.
- Secure the coolant hoses using the supplied hose clamps.
- The other ends of the coolant hoses are connected parallel to the heater hoses by means of T-pieces.
- Ensure there are no kinks in the coolant hoses. Proper and even heat exchange is necessary in order to allow the LPG to evaporate.
- Install the pressure regulator below the highest fluid level of the cooling system to avoid air bubbles.
- Once the system has been installed, the engine must be allowed to warm up so that the heating of the pressure regulator and any eventual coolant leakages can be checked.
- Every time the cooling system is drained, it must be filled and bled in accordance with factory specifications.
- Check the heating of the pressure regulator and for possible water leakage, by letting the engine run idle.

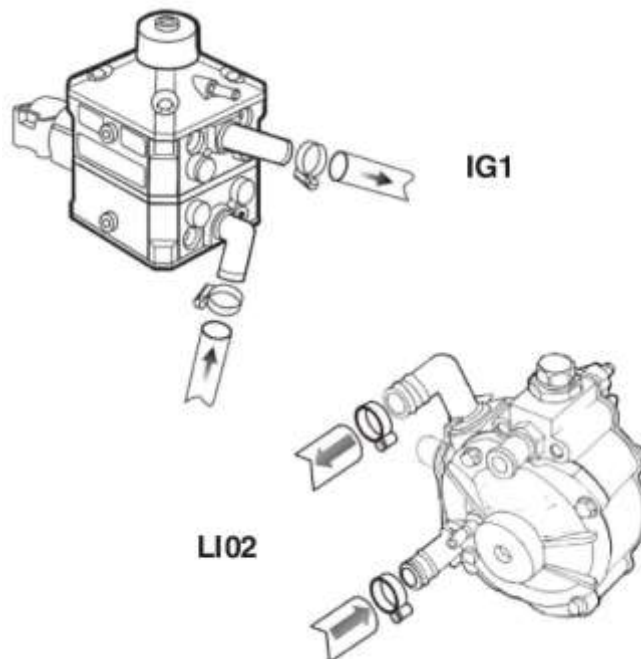





## Gas filter-unit

The filter has the function of filtering the LPG in the gas phase.

The input of the filter is connected to the output of the pressure reducer using a tube with an internal diameter of 14 mm. The filter contains a replaceable filtering

### Technical specifications:

Weight 75 g.

Degree of filtration 10 micron

Maximum working pressure 3 bar

LPG type approval N°: E13 67R-010278 class. 2A

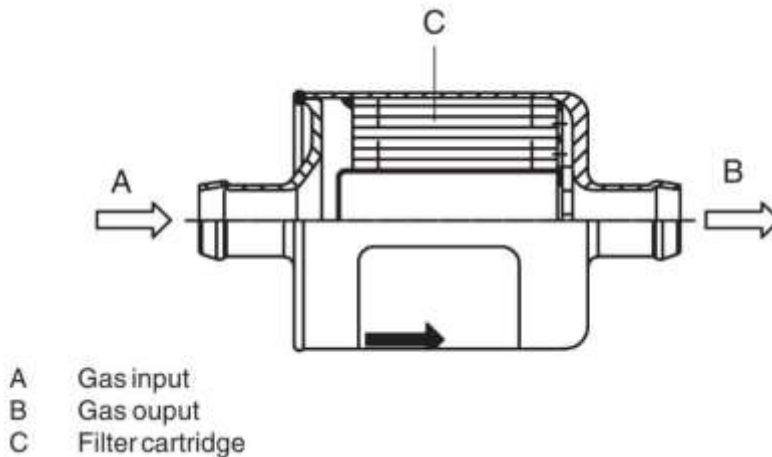

### Filter-unit installation instructions:

- Place the filter unit as close as possible to the injector rail and not too far from the reducer. The maximum length of the tube between reducer and filter is 70 cm, while that between the filter unit and injector rail is 50 cm.
- Avoid the gas tubes passing close to thermal conduction points, in order to protect them and not heat the gas.
- Fit the gas tubes as shown in the figure. The 14-mm tube A on the input coming from the reducer and the 14 mm tube B on the output that brings the gas to the rail.
- The Filter Unit should be easy to reach for maintenance purposes.

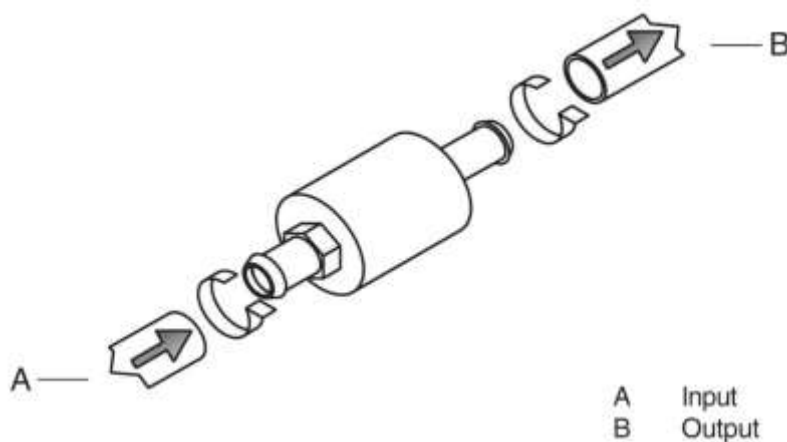



### Injector rail AEBINJ

**Specifications:**

Name:.....AEBINJ  
 Coil tension:.....12V DC  
 Nominal power:.....41W  
 Normally:.....Closed  
 Injectors per rail:.....2, 3 or 4  
 Approval LPG No.:.....E13 67R-010290  
 Approval CNG No.:.....E13 110R-00123



**NOZZLE TABLE FOR LPG POWERED VEHICLES**  
 Information is calculated based on 1 bar pressure

INJECTOR SIZES		kW / Cylinder				
		10 - 15	15 - 20	20 - 25	25 - 30	Over 30
Cc / Cyl.	200 - 280	1.8	1.8			
	290 - 370	1.8	2.0	2.2		
	380 - 440	2.0	2.2	2.2	2.6	2.6
	450 - 500		2.2	2.4	2.6	2.8
	Over 500			2.6	2.8	2.8 / 3.0

**ATTENTION:** 3.0 diameter nozzles have a larger O-ring do not mix with others.

The AEB injector rail is available with 2, 3 or 4 injectors in one complete rail. The outlet nozzle is exchangeable, and is available in different diameters, which makes the rail adjustable for the required power. The table below indicates which nozzle size to use, based on number of cylinders and engine displacement.

**Please check if the nozzle is of the correct diameter!**

- 1) Complete a correct calibration using GAS.
- 2) Bring the vehicle to idle while running on GAS.
- 3) Check the GAS injection time:

The nozzle is correct if the injection time is between 4.5 ms and 6.0 ms, the nozzle is too large if it is under 4.5 ms and too small if it is over 6.0 ms.

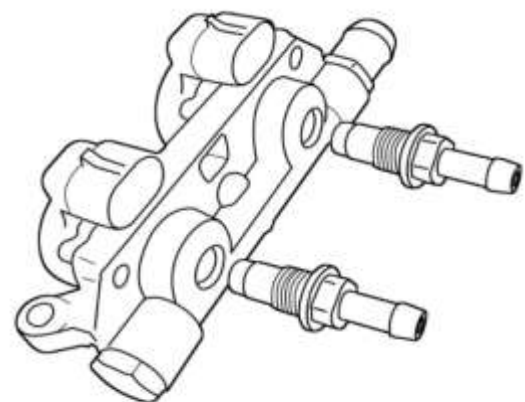
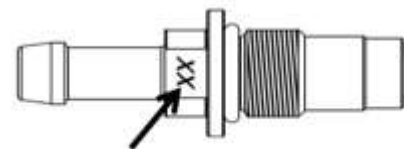

**Legend:**

1. Gas inlet (coming from gasfilter)
2. Injector nozzle (exchangeable)
3. Electric connection per injector (AMP super seal 2 way)
4. Tube connection for gas pressure sensor
5. Rubber bracket for fixation
6. Gas temperature sensor (NTC) (Sicma 2 way connector)



## **Injector rail Valtek Type 34**

### **Specifications:**

Coil tension:.....12V DC  
Nominal power:.....55W  
Normally:.....Closed  
Injectors per rail:.....2, 3 or 4  
Approval LPG No.:..... E4 67R-010196  
Outlet nozzle size:..... Ø 1,5 to 2,8mm  
Injector Layout:..... 2,3,4 cylinders  
Temperature sensor:.....NTC type  
Working temperature:.....-40°C÷120°C  
Maximum service pressure:..... 4,5 bar  
Opening time:..1,7÷1,8 ms @1bar-13,5V  
Closing time:..0,9÷1,0 ms @1bar-13,5V  
Coil resistance:.....2,5±0,1Ω @20°C  
Current control:.....Peak and hold



The Valtek Type 34 injector rail is available with 2, 3 or 4 injectors in one complete rail. The outlet nozzle is exchangeable, and is available in different diameters, which makes the rail adjustable for the required power.

Please refer to the table shown before (Injector rail AEBINJ) that indicates which nozzle size to use, based on power (kW / Cyl.) and engine displacement (cc /Cyl.).





## Injector rail installation instructions

Follow the procedures for installing the injector rail, as shown below:

- The injector rail has two 6mm holes for fitting the unit using the support provided in the kit.
- It will be necessary to place the tubes with the 6-mm interior  $\varnothing$  on the injector output to connect the injector with the nozzle placed on the inlet manifold. (see Chapter that describes the nozzle)
- There is a tight correlation between the location of the injector rail and the nozzles.
- Place the injector rail close to the inlet manifold in such a way that the connection tubes can be as short as possible and so that the nozzles can easily be connected without kinks.
- The injector rail/manifold tubes must be no longer than 18 cm.
- The difference in length between the tubes must not be greater than 4 cm.

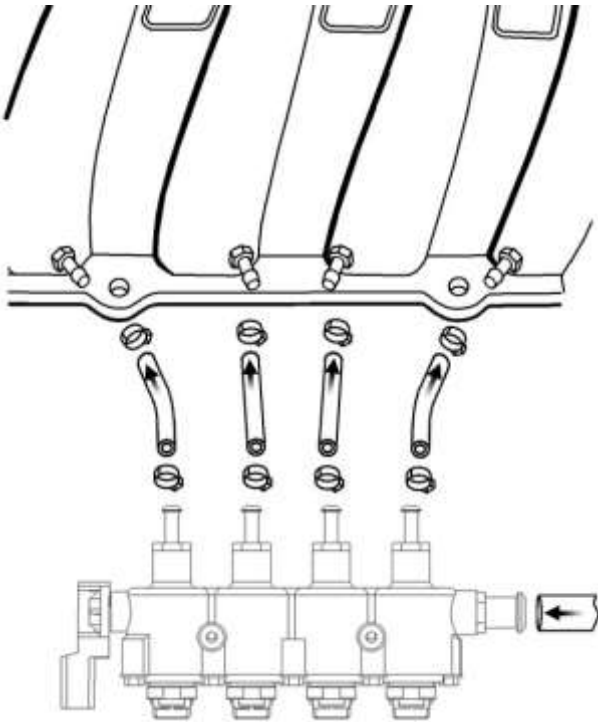

6 cylinder line engine

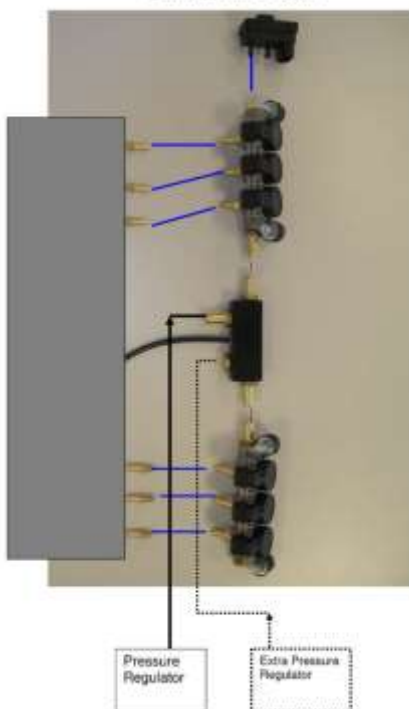

6 cylindre V-engine

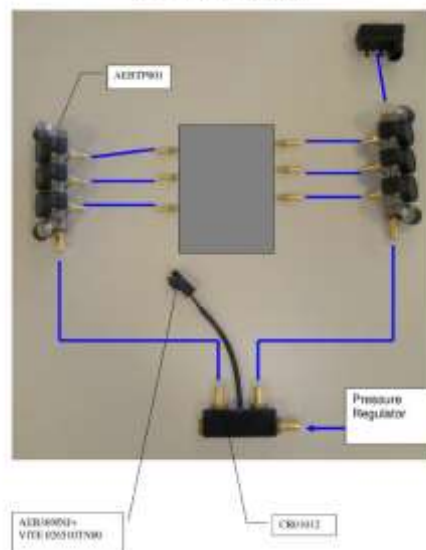

8 Cylindre V-engine

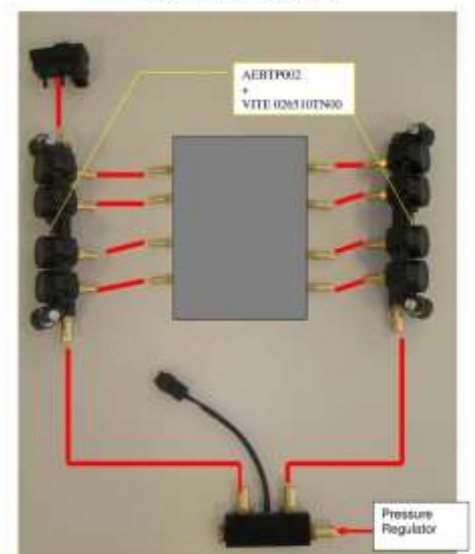



## Nozzles

A nozzle is mounted in each cylinder's individual inlet channel of the inlet manifold and connected to the injectors by means of a suitable tube.

### Technical specifications:

Calibrated pass-through hole:  $\varnothing$  4 mm

Connection to the fuel rail: outside  $\varnothing$  6 mm

Manifold connection: M6 x 1 thread

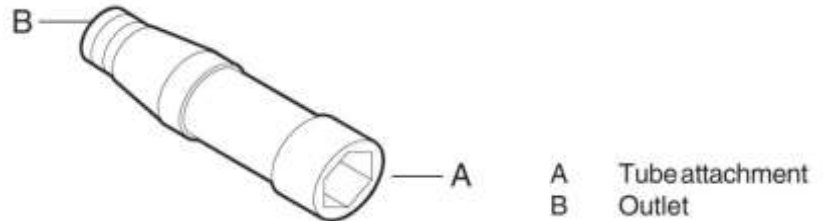

### Nozzle installation instructions:

The correct installation of the nozzles is crucial for the good operation of the engine.

- We advise always to disassemble the inlet manifold before drilling the injector nozzles holes.
- Following the instructions provided on the "vehicle cards," make the holes for installing the nozzles on the manifold.
- In the event that no vehicle card is available to define the positions of the nozzles, place them as close as possible to the petrol injector.
- Mark the points to be drilled.
- Before making the holes, punch the exact points where the holes will be made.
- Apply grease to the point of the drill bit so as to avoid spreading swarf, then drill using a 5-mm bit if the suction manifold is made of aluminum alloy. In the case that the inlet manifold is plastic, use a 4.8 mm bit. During drilling, it is important to keep the drill in a perpendicular position with respect to the surface to be drilled.
- Tap a thread with a male M6x1.
- Carefully clean the inlet manifold and remove all the drilling swarf.
- Take care not to damage the threads in tightening the fittings.
- Use a drop of brake thread sealant in the coupling to improve the grip.
- Reassemble the inlet manifold and use new manifold gaskets, if necessary reassemble all the components previously removed during the course of the dismantling operation.



### Optional Nozzle Extension kit:

In the case it is not possible to install the injector nozzles close to the original petrol injectors, we advise to use a nozzle extension kit. This allows you to enter the manifold more distance and continue with the gas pipe in the manifold.

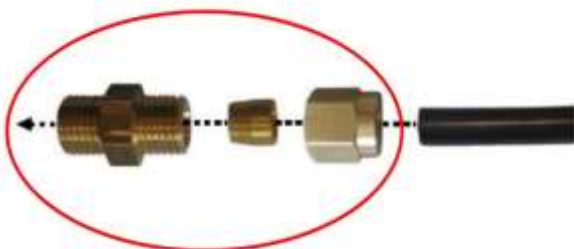



### **Water temperature sensor**

This sensor is used to measure the engine temperature. This signal is used by the ECU to determine when to switch over to gas.

The electric signal is sent to the ECU as part of a string of information necessary for the engine running on gas.

#### **Technical specifications:**

Weight 71 g.

Tube connection 15 mm

Sensor type 4.7 ohm

Connector IP 54 type SICMA 2

#### **Legend:**

1. Water hose connections
2. NTC temperature sensor
3. Electrical connection

#### **Installation instruction Temp. sensor:**

The temperature sensor is fitted on the cooling circuit just upstream of the pressure regulator.

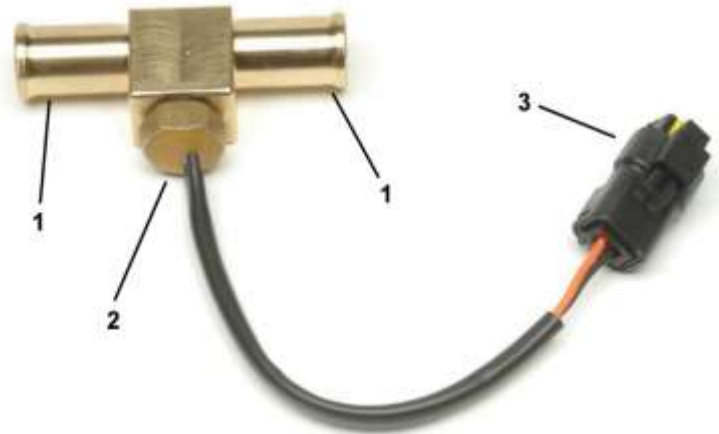



### Pressure- MAP-sensor AEB025

This component is used in Gas vehicles. It measures the gas pressure after pressure regulator and vacuum in the manifold. The pressure signals are changed in electrical signals in the way that they can be analyzed by ECU. The AEB 025 Double Map sensor is suitable to manage two different pressure signals: one from manifold (V) and one from injector rail gas pressure.

**Specifications:**

Name: AEB025

LPG type approval N°: E3 67R-0158464

There are 2 versions of the Pressure – MAP sensor:

- AEB025 In Line Sensor
- AEB025 T-connection

**AEB025 In Line Sensor**

The five wire connection (with 5way superseal connector) is for :

- +5V feeding
- Ground
- Vacuum signal (0 – 2,5 bar)
- Pressure signal (0-4,5 bar) Class2
- Gas Temperature NTC (-20 – 120C)

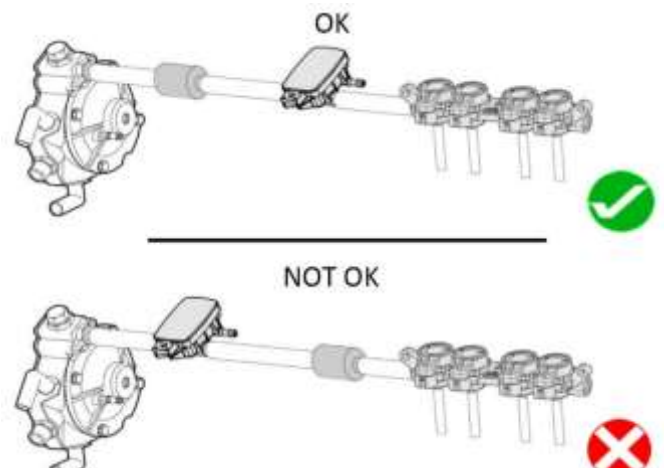
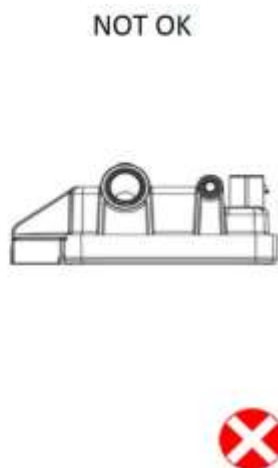
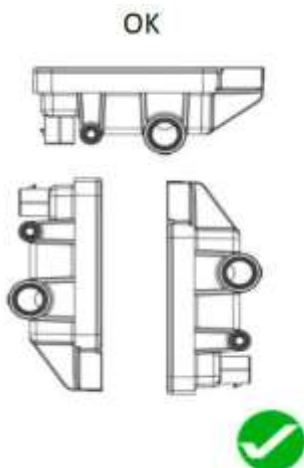
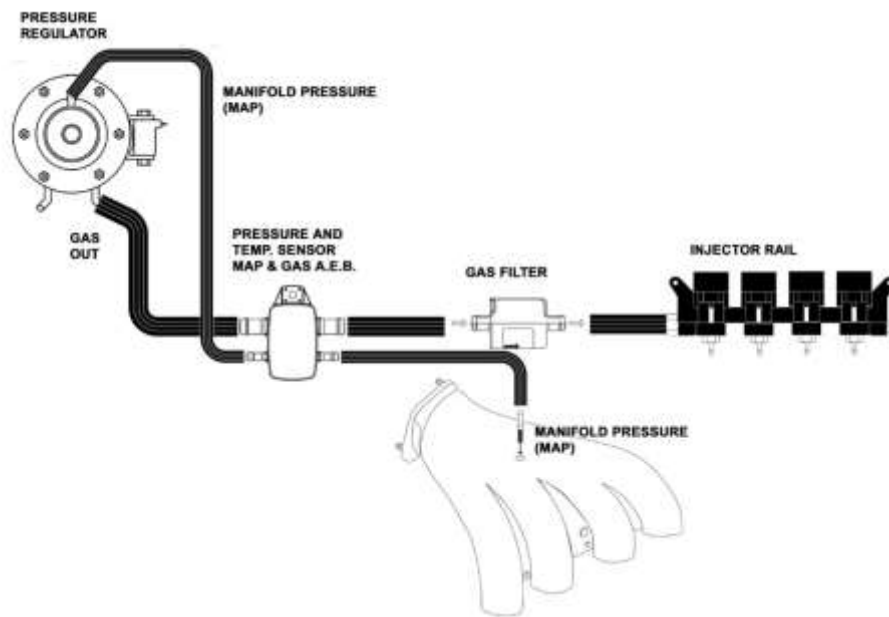
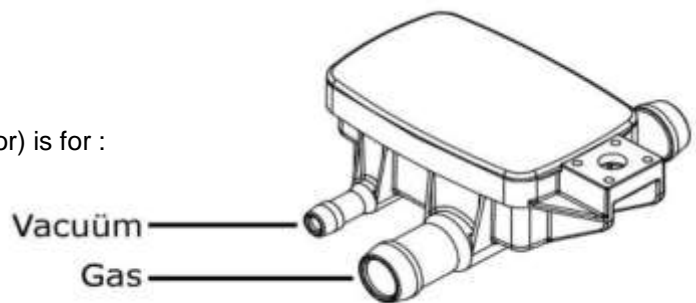



## AEB025 T-connection

The four wire connection (with 4way superseal connector) is for :

- +5V feeding
- Ground
- Vacuum signal (0 – 2,5 bar)
- Pressure signal (0-4,5 bar) Class2

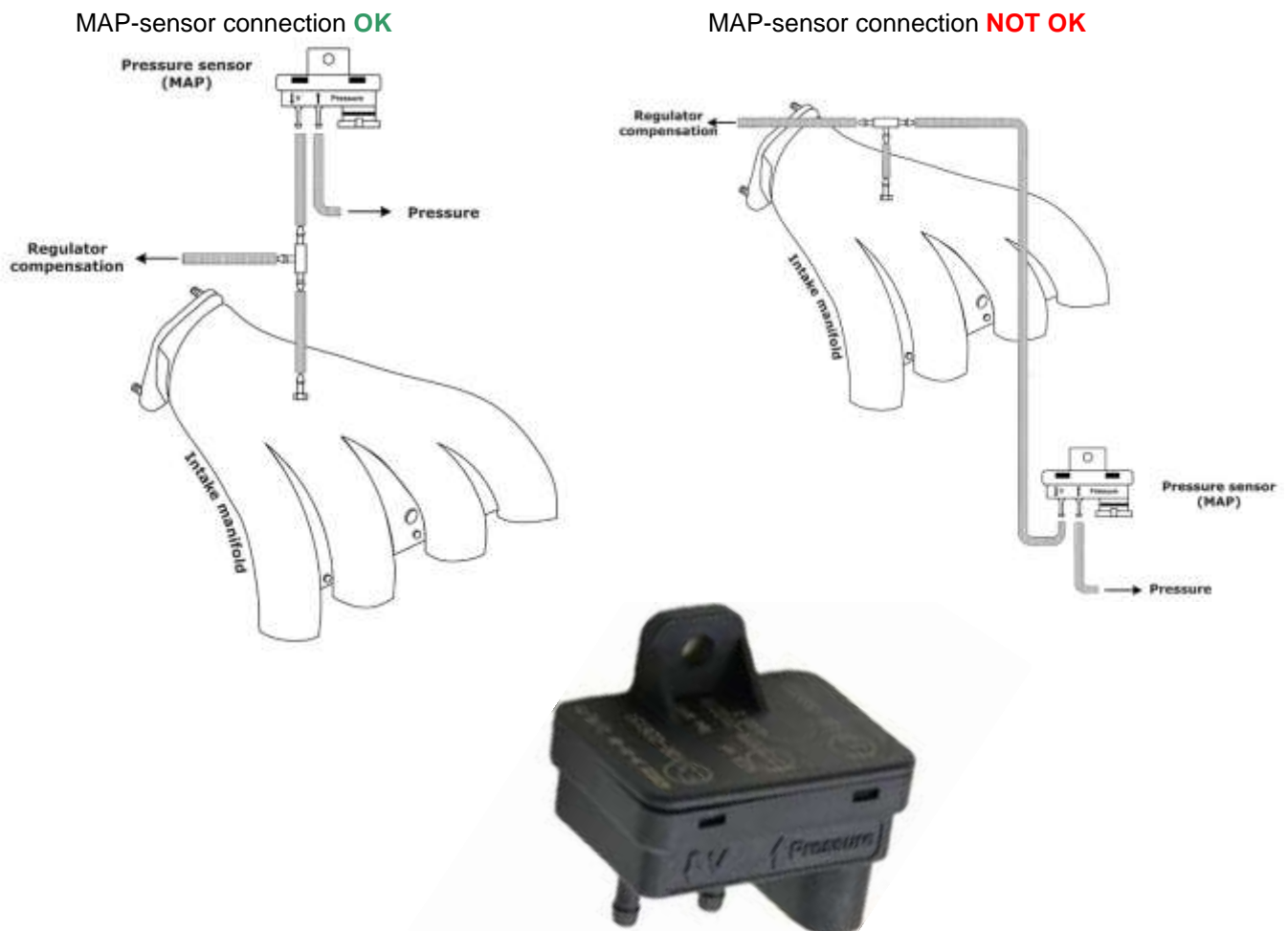

### General installation guidelines:

- Check whether an original unused connection point is available.
- If no such point is available;
- Detach the inlet manifold, ensuring that the gasket is not damaged and take note of any components and connections.
  - Determine the position of the vacuum connection that will be made in accordance with the specific installation instructions.
  - If not explicitly specified in the installation instructions, personally determine an easily accessible connection point, preferably just behind the throttle valve.
  - First determine the centre before drilling the hole.
  - Apply some grease around the drill bit to prevent the shavings from flying around and drill a 4.8-mm hole in case of an aluminium manifold and a 4.5-hole in case of a plastic manifold. While drilling, it is important that the drill is held at a right angle to the surface.
  - Tapping screw thread M6x1.
  - Carefully remove all drill shavings.
  - Install the vacuum connecting nipple using sealant/adhesive fluid.





### Gas-ECU

The Electronic Control Unit (ECU), also referred to as the brain of the system, controls the system. The key functions of the gas system ECU are:

1. Detection and processing of original engine management signals:
  - a) Petrol injectors
  - b) Coolant temperature
  - c) Engine RPM
  - d) On-board voltage
  - e) OBD-communication (Option)
2. Detection and processing of gas system signals:
  - a) Gas pressure
  - b) Manifold pressure
  - c) Gas temperature
  - d) Tank level sensor
  - e) Selected fuel type
3. Controlling of flow valves
4. Controlling of gas injectors
5. Deactivation of petrol injectors
6. Serial communication with the selector switch
7. LPG level indication
8. Controlling of buzzer
9. System monitoring and diagnosis
10. Communication with interface software (PC).

The firmware (software strategy) memory and the configuration memory can both be reprogrammed. This means that in the case of software upgrades, management strategy and calibration can be modified by reprogramming the memory of the ECU.

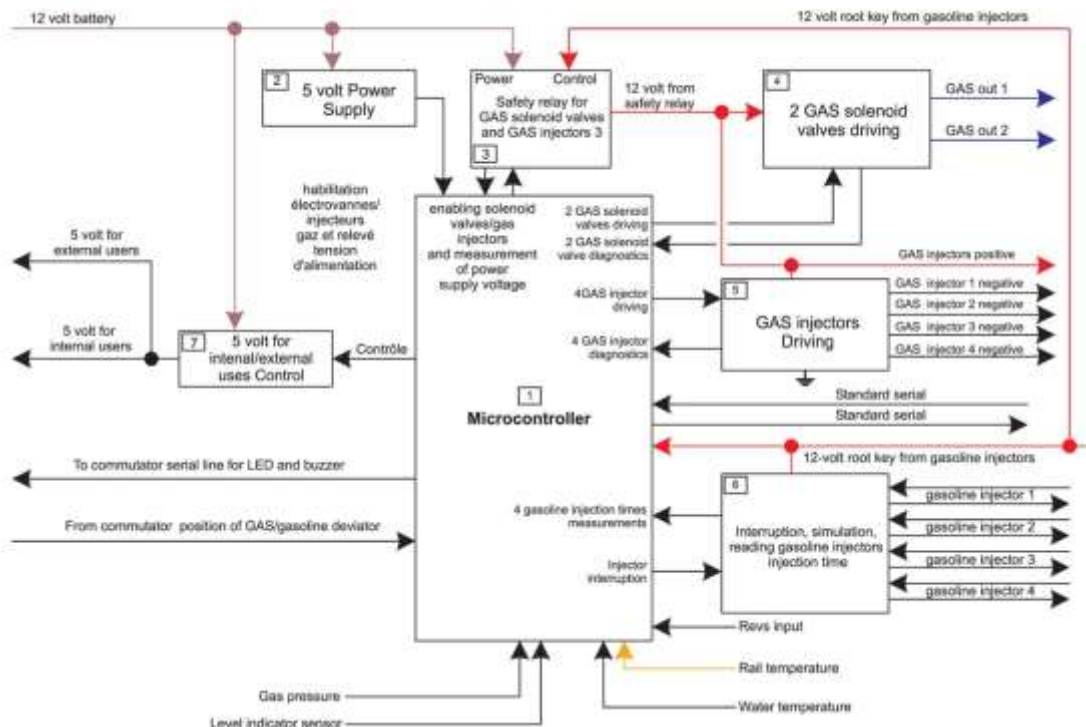

There are 3 different hardware versions available. The choice depends on the application, size of the engine and the budget of the installation.

- AEB 4 Cyl. MP48 (OBD)
- AEB2001 4 Cyl. (OBD)
- AEB2568D 8 Cyl. (OBD)



**ECU VGI 4 Cyl. AEB MP48 (OBD)**

Multipoint 4-cylinder timed sequential injection control unit with optional OBDII function

The VGI AEB MP48 control unit with LPG sequential injection and OBDII integration are one step ahead of the current control units installed on modern vehicles with indirect sequential injection.

These evolved control units allow information to be received from the original petrol control unit via the OBDII diagnostics outlet, pursuant to the protocols of standards ISO9141 and ISO15765. Thanks to this connection, when running on gas, the AEB control unit is able to monitor vehicle carburetion parameters constantly (thanks to the petrol control unit correctors), thus keeping the parameters at optimum values.

This integration means:

- better engine performance;
- guaranteed top performance even when the mechanical components of the gas fuel system age;
- automatic adaptation to the different gas qualities available on the market;
- more information available to the installer regarding vehicle function which makes tuning the system easier.

**Specifications:**

- Homologation LPG No.: E13 67R-010157
- Supply voltage:  $V_{batt}=10\div 16V$
- Operating temperature:  $-40\div 120^{\circ}C$
- Current absorption with the actuators disabled:  $I_{max}=0.5A$
- Current absorption in the standby mode:  $I_{standby} < 5\mu A$

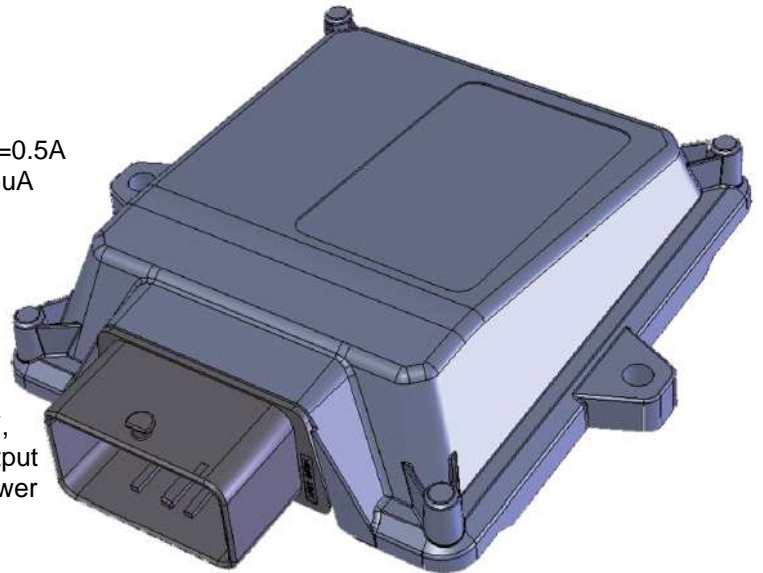

**Actuators managed:**

- 2 to 4 gas injectors with the following characteristics  $I_{max}=6$ ,  $V_{batt,max}=16V$
- 2 power outputs for gas solenoid valves [ $P_{max}=25W$ ,  $I_{max}=2,5 A$  (power and maximum current for each output with two outputs enabled) -  $P_{max}=50W$ ,  $I_{max}=4A$  (power and maximum current with just one output enabled)]

**Sensors managed:**

- Gas pressure sensor: AEB025 In Line Sensor
- MAP sensor: AEB025 In Line Sensor
- Level sensor: AEB level sensor, standard sensor 0-90Ohm, non standard sensor
- Reduction gear temperature sensor: AEB sensor, type 369
- Gas temperature sensor: ABE type sensor (4.7kOhm), sensor (2.2kOhm), sensor 1kOhm
- Pre-catalytic converter Oxygen sensor: 0-1V, 0-5V, 5-0V, 0.8-1.6V, 2.5-3.5V, UEGO (linear sensor in current)
- Post-catalytic converter Oxygen sensor: 0-1V
- Management of AEB119B type switch

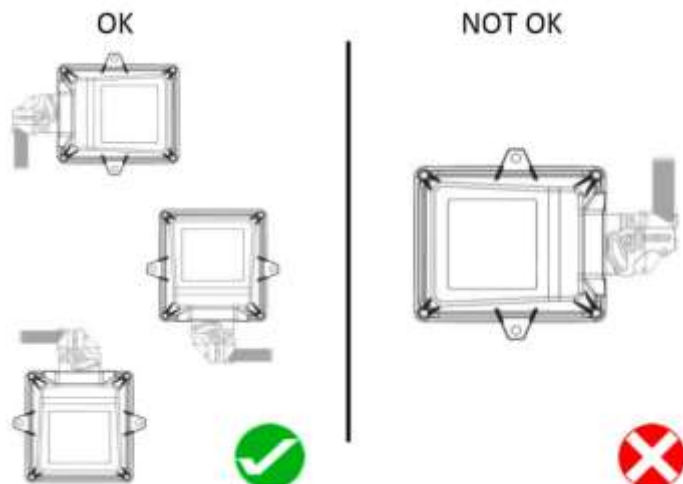





### ELECTRICAL CONNECTIONS ECU VGI 4 Cyl. AEB MP48

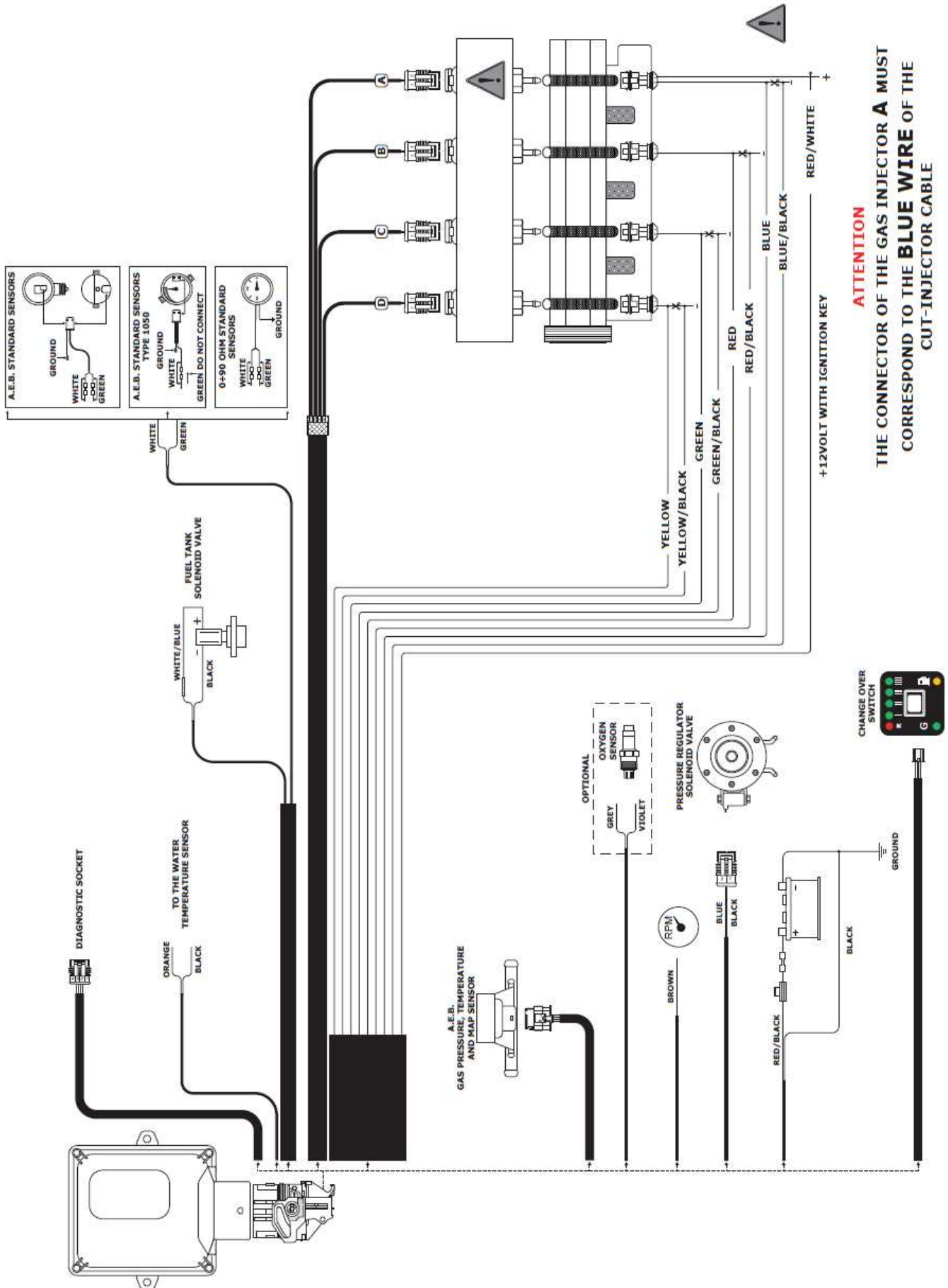



### ELECTRICAL CONNECTIONS ECU VGI 4 Cyl. AEB MP48 OBD

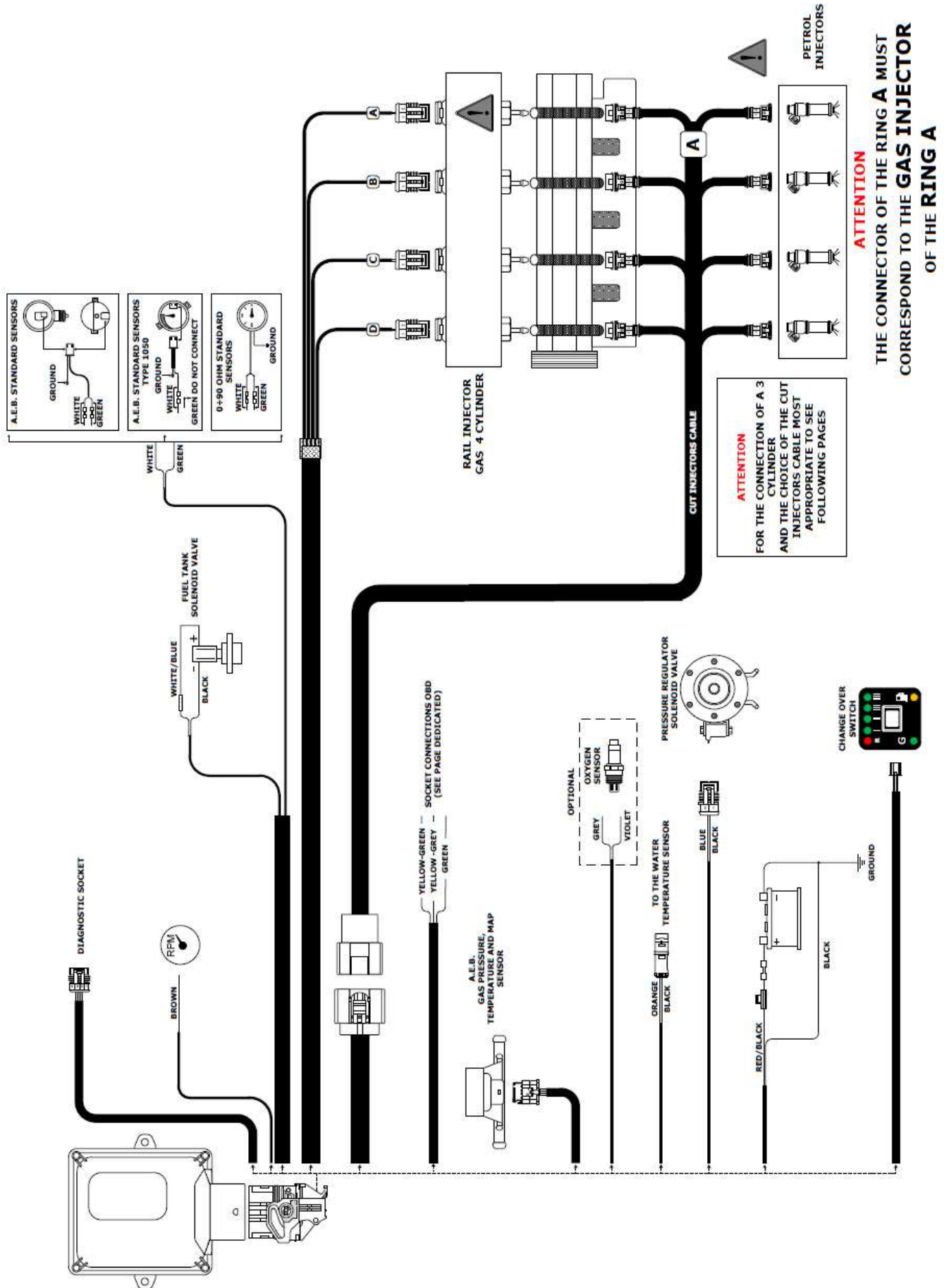



## **ECU VGI 4 Cyl. AEB2001NC OBD**

Multipoint 4-cylinder timed sequential injection control unit with OBDII function

The VGI AEB2001NC control unit with LPG sequential injection and OBDII integration are one step ahead of the current control units installed on modern vehicles with indirect sequential injection.

These evolved control units allow information to be received from the original petrol control unit via the OBDII diagnostics outlet, pursuant to the protocols of standards ISO9141 and ISO15765. Thanks to this connection, when running on gas, the AEB control unit is able to monitor vehicle carburetion parameters constantly (thanks to the petrol control unit correctors), thus keeping the parameters at optimum values.

This integration means:

- better engine performance;
- guaranteed top performance even when the mechanical components of the gas fuel system age;
- automatic adaptation to the different gas qualities available on the market;
- more information available to the installer regarding vehicle function which makes tuning the system easier.

### **Specifications:**

- Homologation LPG No.: E13 67R-010157
- Supply voltage:  $V_{batt}=10\div 16V$
- Operating temperature:  $-40\div 120^{\circ}C$
- Current absorption with the actuators disabled:  $I_{max}=0.5A$
- Current absorption in the standby mode:  $I_{standby} < 5\mu A$

### **Actuators managed:**

- 3 or 4 gas injectors with the following characteristics  
 $I_{max}=6$ ,  $V_{batt,max}=16V$
- 2 power outputs for gas solenoid valves [ $P_{max}=25W$ ,  
 $I_{max}=2A$  (power and maximum current for each output with two outputs enabled) -  $P_{max}=50W$ ,  $I_{max}=4A$  (power and maximum current with just one output enabled)]



### **Sensors managed:**

- Gas pressure sensor: AEB025 T-connection
- MAP sensor: AEB025, T-connection
- Level sensor: AEB level sensor, standard sensor 0-90Ohm, non standard sensor
- Reduction gear temperature sensor: AEB sensor, type 369
- Gas temperature sensor: ABE type sensor (4.7kOhm), sensor (2.2kOhm), sensor 1kOhm
- Pre-catalytic converter Oxygen sensor: 0-1V, 0-5V, 5-0V, 0.8-1.6V, 2.5-3.5V, UEGO (linear sensor in current)
- Post-catalytic converter Oxygen sensor: 0-1V
- Management of AEB119B type switch



### PIN-OUT ECU VGI 4 Cyl. AEB2001NC

BLACK CONNECTOR											
PIN	DESCRIPTION	WIRE SECTION	Colour	PIN	DESCRIPTION	WIRE SECTION	Colour	PIN	DESCRIPTION	WIRE SECTION	Colour
1A	Battery Positive Pole	1,50 mm <sup>2</sup>	red-black	1B	Battery Negative Pole (GROUND)	2,50 mm <sup>2</sup>	black	1C	Gas solenoid 1 Control	1,50 mm <sup>2</sup>	blue
2A	Serial PC interface Power Supply	0,50 mm <sup>2</sup>	red-black	2B	Serial PC interface Ground	0,50 mm <sup>2</sup>	black	2C	Gas solenoid 1 Ground	1,50 mm <sup>2</sup>	black
3A	Transmission of serial data (TX)	0,50 mm <sup>2</sup>	pink	3B	Reception of serial data (RX)	0,50 mm <sup>2</sup>	pink	3C	Temperature sensors Ground	0,75 mm <sup>2</sup>	black
4A	GAS level sensor	0,50 mm <sup>2</sup>	white	4B	GAS level sensor Power Supply	0,50 mm <sup>2</sup>	green	4C	Regulator temperature sensor	0,75 mm <sup>2</sup>	orange
5A	Fuel switch position	0,50 mm <sup>2</sup>	blue	5B	Fuel switch Ground	0,50 mm <sup>2</sup>	black	5C	GAS temperature sensor	0,75 mm <sup>2</sup>	orange-black
6A	Fuel switch communication line	0,50 mm <sup>2</sup>	brown	6B	Fuel switch Power Supply	0,50 mm <sup>2</sup>	red	6C	CAN-L (OBD communication line)	0,50 mm <sup>2</sup>	grey-yellow
7A	Engine RPM	0,75 mm <sup>2</sup>	brown	7B	Not used			7C	Not used		
8A	CAN-H (OBD communication line)	0,75 mm <sup>2</sup>	yellow-green	8B	Not used			8C	Not used		

GREY CONNECTOR											
PIN	DESCRIPTION	WIRE SECTION	Colour	PIN	DESCRIPTION	WIRE SECTION	Colour	PIN	DESCRIPTION	WIRE SECTION	Colour
1A	GAS Injector C Positive	1,00 mm <sup>2</sup>	red	1B	GAS Injector B Positive	1,00 mm <sup>2</sup>	red	1C	Gas solenoid 1 Control	1,00 mm <sup>2</sup>	red
2A	GAS Injector D Negative	1,00 mm <sup>2</sup>	white-black	2B	GAS Injector A Negative	1,00 mm <sup>2</sup>	brown-white	2C	Gas solenoid 1 Ground	1,00 mm <sup>2</sup>	red
3A	GAS Injector C Negative	1,00 mm <sup>2</sup>	white-red	3B	GAS Injector B Negative	1,00 mm <sup>2</sup>	blue-white	3C	Temperature sensors Ground	0,75 mm <sup>2</sup>	red-black
4A	Petrol Injector Negative A (Inj. side)	0,75 mm <sup>2</sup>	blue	4B	Petrol Injector Negative A (ECU side)	0,75 mm <sup>2</sup>	blue-black	4C	Regulator temperature sensor	0,75 mm <sup>2</sup>	red
5A	Petrol Injector Negative D (Inj. side)	0,75 mm <sup>2</sup>	yellow	5B	Petrol Injector Negative C (ECU side)	0,75 mm <sup>2</sup>	turquoise-black	5C	GAS temperature sensor	0,75 mm <sup>2</sup>	turquoise
6A	Petrol Injector Negative D (ECU side)	0,75 mm <sup>2</sup>	yellow-black	6B	Mainfold Absolute Pressure (MAP) sensor	0,50 mm <sup>2</sup>	yellow-red	6C	CAN-L (OBD communication line)	0,50 mm <sup>2</sup>	red-black
7A	Key ON Engine OFF	0,75 mm <sup>2</sup>	white-red	7B	GAS pressure sensor	0,50 mm <sup>2</sup>	brown-black	7C	Oxygen sensor emulation	0,50 mm <sup>2</sup>	black
8A	GAS solenoid 2 Control	1,50 mm <sup>2</sup>	blue-white	8B	K-L ine (OBD communication line)	0,50 mm <sup>2</sup>	green	8C	Oxygen sensor Reading	1,50 mm <sup>2</sup>	black





### ELECTRICAL CONNECTIONS ECU VGI 4 Cyl. AEB2001NC

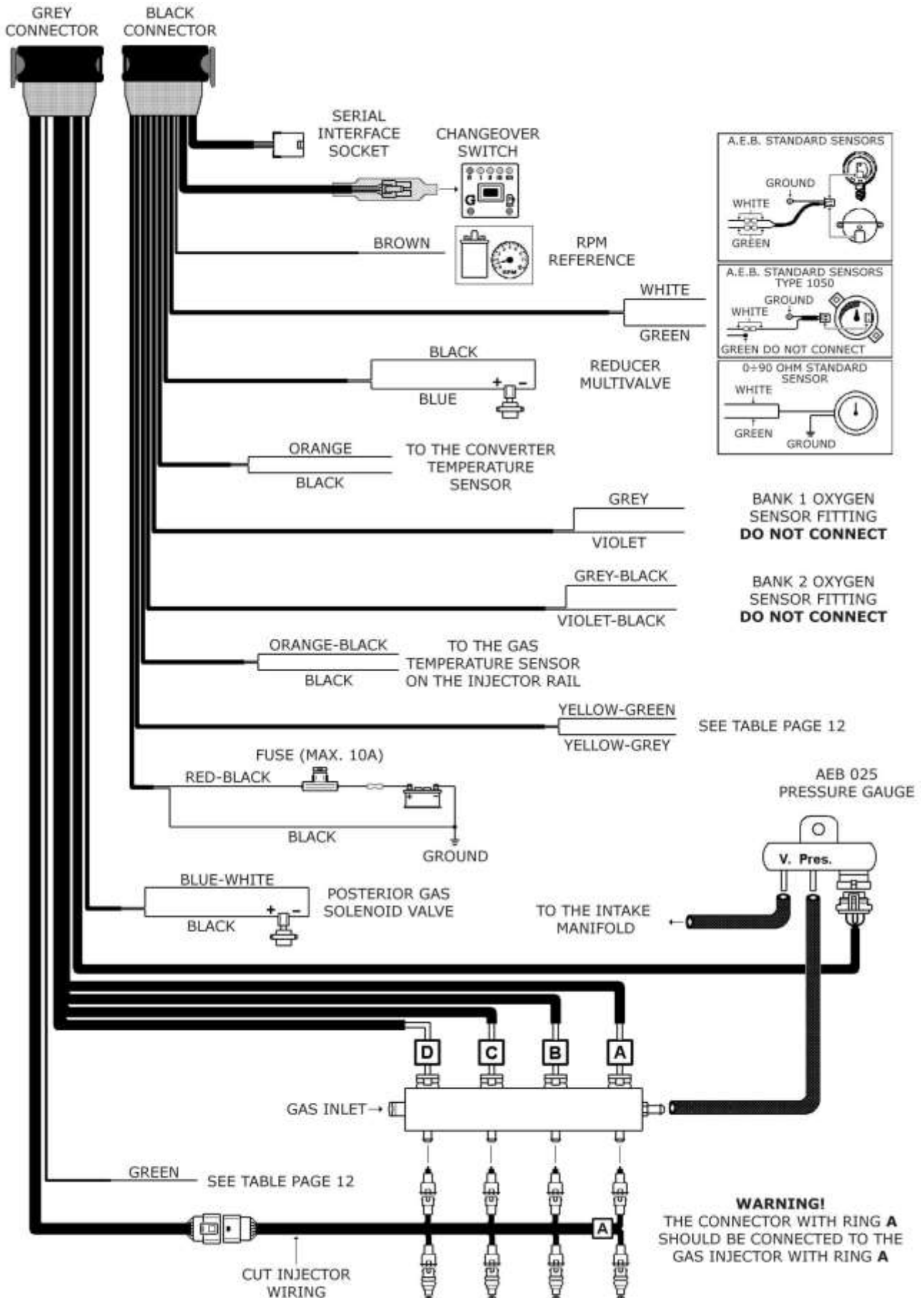



## **ECU VGI 8 Cyl. AEB2568D OBD**

Multipoint 8-cylinder timed sequential injection control unit with OBDII function

The VGI AEB2568D control unit with LPG sequential injection and OBDII integration are one step ahead of the current control units installed on modern vehicles with indirect sequential injection.

These evolved control units allow information to be received from the original petrol control unit via the OBDII diagnostics outlet, pursuant to the protocols of standards ISO9141 and ISO15765. Thanks to this connection, when running on gas, the AEB control unit is able to monitor vehicle carburetion parameters constantly (thanks to the petrol control unit correctors), thus keeping the parameters at optimum values.

This integration means:

- better engine performance;
- guaranteed top performance even when the mechanical components of the gas fuel system age;
- automatic adaptation to the different gas qualities available on the market;
- more information available to the installer regarding vehicle function which makes tuning the system easier.

Legend:

1. Fixation points
2. Connector (56 Pins)
3. ECU Type identification
4. ECU Type identification

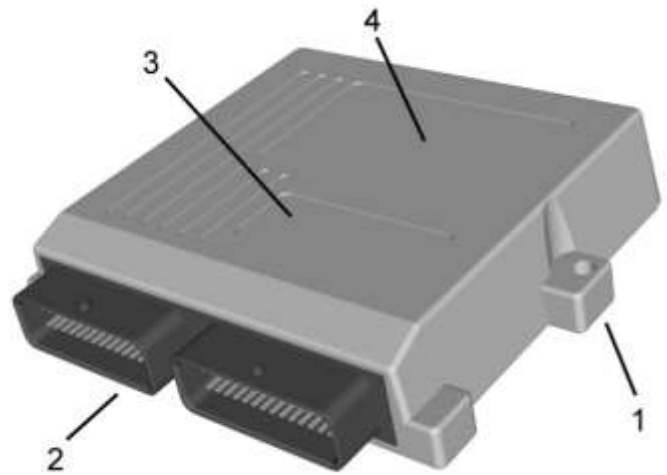

### **Specifications:**

- Homologation LPG No.: E3 67R-016019
- Supply voltage:  $V_{batt}=10\div 16V$
- Operating temperature:  $-40\div 120^{\circ}C$
- Current absorption with the actuators disabled:  $I_{max}=0.5A$
- Current absorption in the standby mode:  $I_{standby} < 5\mu A$

### **Actuators managed:**

- 4 to 8 gas injectors with the following characteristics  
 $I_{max}=6$ ,  $V_{batt,max}=16V$
- 2 power outputs for gas solenoid valves [ $P_{max}=25W$ ,  
 $I_{max}=2A$  (power and maximum current for each output with two outputs enabled) -  $P_{max}=50W$ ,  $I_{max}=4A$  (power and maximum current with just one output enabled)]

### **Sensors managed:**

- Gas pressure sensor: AEB025 T-Connection
- MAP sensor: AEB025, the car's original sensor (to be characterised)
- Level sensor: AEB level sensor, standard sensor 0-90Ohm, non standard sensor
- Reduction gear temperature sensor: AEB sensor, type 369
- Gas temperature sensor: ABE type sensor (4.7kOhm), sensor (2.2kOhm), sensor 1kOhm
- Pre-catalytic converter Oxygen sensor: 0-1V, 0-5V, 5-0V, 0.8-1.6V, 2.5-3.5V, UEGO (linear sensor in current)
- Post-catalytic converter Oxygen sensor: 0-1V
- Management of AEB119B type switch



**PIN-OUT ECU VGI 8 Cyl. AEB2568D**

**Connector VGI 8 CIL**

		PIN	PIN		
RED	LPG INJECTOR C	28	56	LPG INJECTOR A	YELLOW
BROWN	LPG INJECTOR D	27	55	LPG INJECTOR B	ORANGE
YELLOW	LPG INJECTOR E	26	54		EMPTY
ORANGE	LPG INJECTOR F	25	53		EMPTY
RED	LPG INJECTOR G	24	52		EMPTY
BROWN	LPG INJECTOR H	23	51		EMPTY
BLACK	GROUND SWITCH+COILS	22	50	GROUND	BLACK
BLACK	+12V LPG INJECTORRAIL 2	21	49	+12V LPG INJECTORRAIL 2	BLACK
	EMPTY	20	48	SWITCH	BLUE
WHITE/BLUE	+12 V. COIL TANK	19	47	SWITCH	BROWN
BLUE	12 VOLT COILS	18	46	+ SWITCH	RED
	EMPTY	17	45	INTERFACE	ROSE/BLACK
	EMPTY	16	44	INTERFACE	ROSE
RED/BLACK	+ ACCU	15	43	+ ACCU	RED/BLACK
		PIN	PIN		
YELLOW/BLACK	PETROL ECU CIL 8	14	42	PETROL INJECTOR CIL 8	YELLOW
GREEN	PETROL INJECTOR CIL 7	13	41	+CONTACT	WHITE/RED
GREEN/BLACK	PETROL ECU CIL 7	12	40	RPM SENSOR	BROWN
RED	PETROL INJECTOR CIL 6	11	39	PRESSURE SENSOR	ORANGE BLACK
RED/BLACK	PETROL ECU CIL 6	10	38	PRESSURE SENSOR	YELLOW/RED
BLUE	PETROL INJECTOR CIL 5	9	37	TEMP REDUCER	ORANGE
BLUE/BLACK	PETROL ECU CIL 5	8	36	TEMP INJECTORRAIL	ORANGE/BLACK
YELLOW	PETROL INJECTOR CIL 4	7	35	TANK SENSOR	WHITE
YELLOW/BLACK	PETROL ECU CIL 4	6	34	TANK SENSOR	GREEN
GREEN	PETROL INJECTOR CIL 3	5	33	ECU LAMBDA	GREY
GREEN/BLACK	PETROL ECU CIL 3	4	32	LAMBDA	PAARS
RED	PETROL INJECTOR CIL 2	3	31	ECU LAMBDA 2	GREY/BLACK
RED/BLACK	PETROL ECU CIL 2	2	30	LAMBDA 2	PAARS/BLACK
BLUE	PETROL INJECTOR CIL 1	1	29	PETROL ECU CIL 1	BLUE/BLACK





### ELECTRICAL CONNECTIONS ECU VGI 8 Cyl. AEB2568D

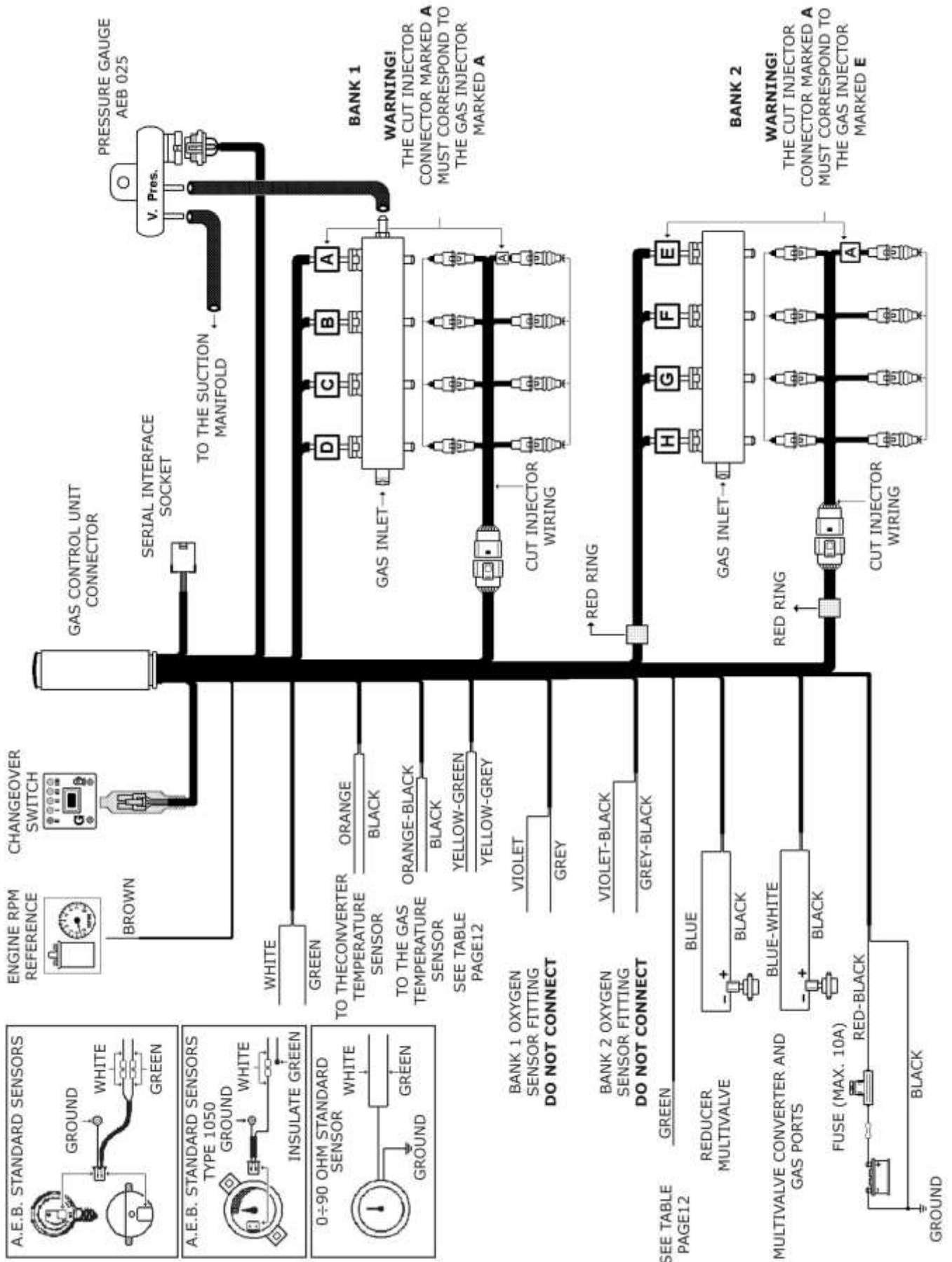



## GAS ECU Installation Instructions

- Install the gas system ECU in the engine bay or in the passenger compartment in accordance with the regulations specified in the specific vehicle installation instructions. It can be mounted directly on the body or by means of a support.
- Keep the gas system ECU as far away as possible from heat sources such as the exhaust, radiator etc., and protect it from splashes.
- Bear in mind that the connector must be attachable and detachable.
- Attach the connector by pressing it on with pushed out lock tab.
- Then push in the connector lock and the connector will be pulled tightly against the gas system ECU and locked.



- FAR from any **WATER LEAKAGE**



- FAR from **EXCESSIVE HEAT SOURCES** (such as exhaust manifolds).



- FAR from **HIGH-VOLTAGE CABLES.**



Create efficient electrical connections without using any "POWER TAPS".  
**Properly insulated soldering is the most effective type of electrical connection.**



**Advise the customer that if the GAS system fuse burns, the connections of the devices to which it is connected will be restored. It is strongly recommended not to replace the fuse with another one with a higher amperage rating since it may cause irreparable damage.**



Do not open the Control Unit box for any reason, especially when the engine is running or the key is in the ignition, to avoid irreparable damage.  
**A.E.B. will not be held responsible for damage to property or injuries to persons if unauthorised personnel tamper with its devices; such tampering will also invalidate the WARRANTY.**

### How to install the Control Unit

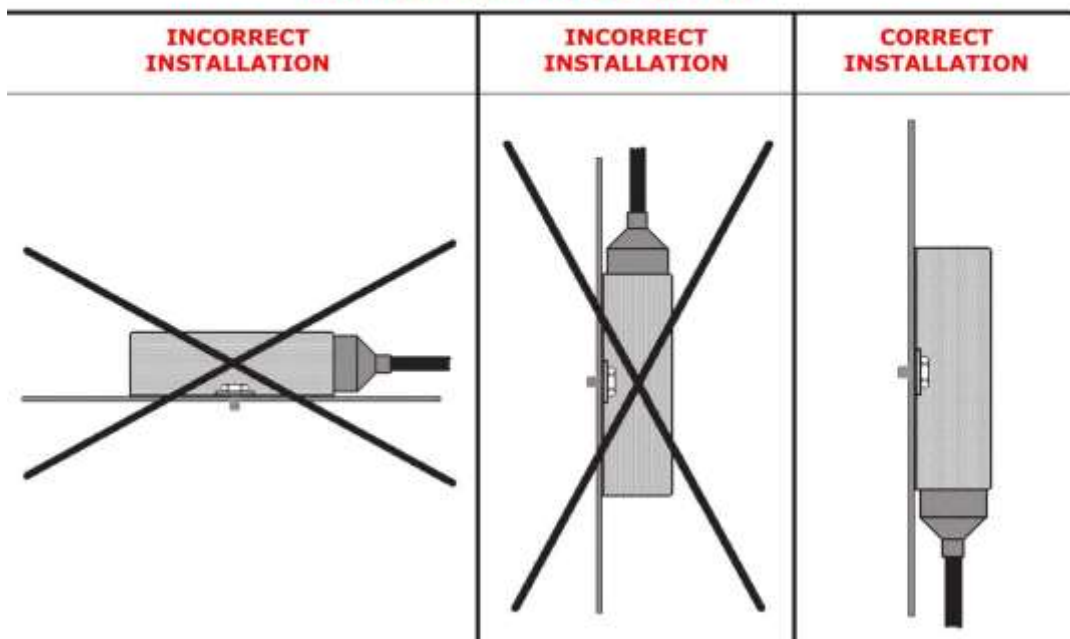



## **Electrical Installation Instructions:**

The majority of electrical connections are realised via the preassembled wire harness with connectors. The following applies to electrical connections:

- Follow the diagrams for the relevant installation instructions.
- Keep the wire harness as far away as possible from heat sources such as the exhaust, radiator, etc.
- Keep the wire harness away from moving components such as the cooling fan and shift mechanism.
- Keep the wire harness as far away as possible from high-voltage components such as the ignition system.
- Where possible, follow the route of the original wiring and attach the Eurogas Omegas wire harness carefully using binding strips. All of this is essential for providing access to components during maintenance work.
- Wire to wire connections should be soldered and well isolated, to prevent corrosion in a later stage.
- Wire to contacts and terminal connections be soldered and well isolated, to prevent corrosion in a later stage.
- Use a shrink sleeve on connections that have been soldered.
- Connect the 12-V power supply to the positive terminal of the battery.
- Connect the potential mass to the negative terminal of the battery.
- Connect the reference earth to the reference earth of a vehicle such as the negative terminal of the battery or chassis.

## **Fuse Installation Instructions**

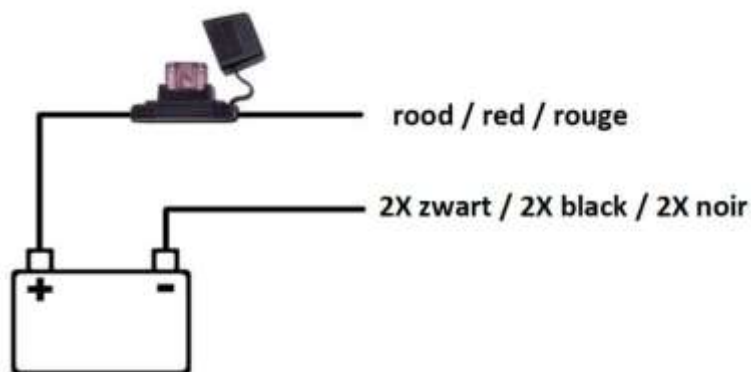

Fuse is used to protect the system from oversized current. It has to be fitted near the car battery in order to be detected easily. Preferably fix the fuse at the top of the battery. The maximum acceptable current is 15A.

## **Engine Speed Signal Installation Instructions**

The brown wire of the loom has to be soldered to the signal wire of the ignition coil.

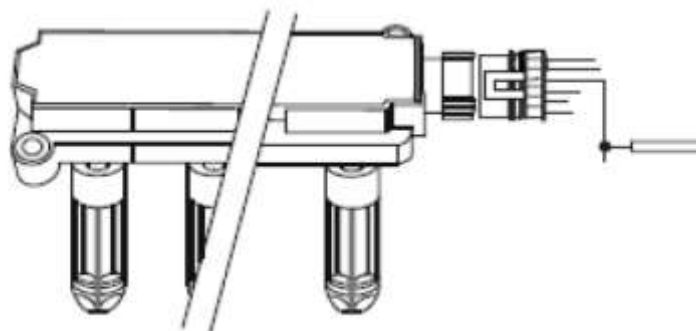



## Connection to the AEB025 Sensor

Connect the pressure / MAP connector to the AEB025 sensor. Pay attention! The connector only fits in one correct position.

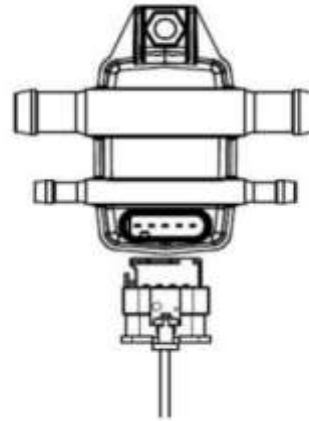

## Lambda Signal connection

To obtain the lambda signal in the interface software (which can help you to calibrate the car), connect the purple wire to the lambda signal wire.

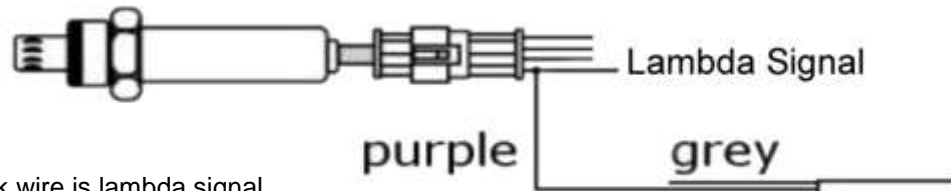

Bosch Sensor 4 wire: Black wire is lambda signal  
Denso / NTK Sensor 4 wire: Blue wire

Connect to the lambda probe pre-catalyst! Don't connect the grey wire!

## Tank wire connections

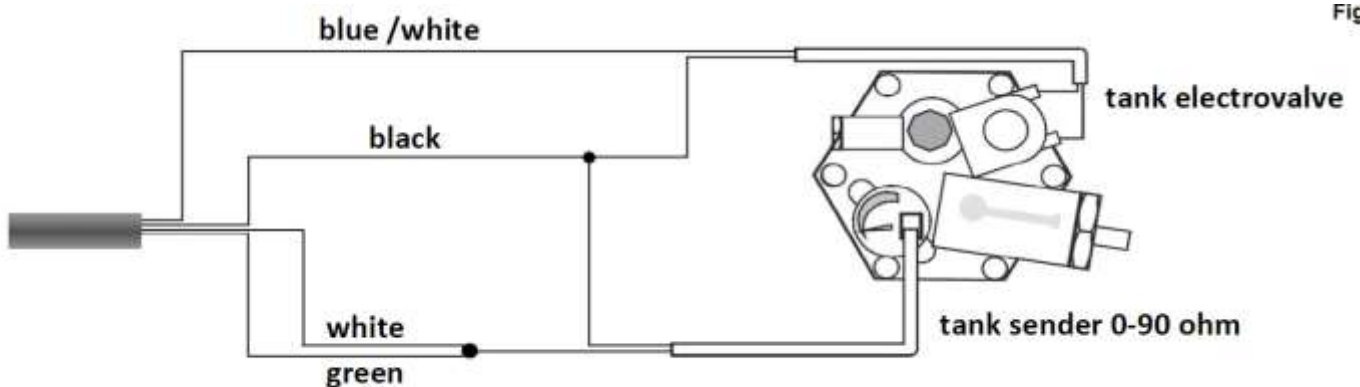



## Injection Signal Cutting Installation Instructions:

### How to check which cut injector wiring to use

There are different types of cut injector wiring to match with the injection control unit:

**SA144 / SA143:** Injection cutting wiring with standard connectors (Bosch) 4 Cylinder / 3 Cylinder.

**SA144INV / SA143INV :** Injection cutting wiring with inverted connectors (Bosch) 4 Cylinder / 3 Cylinder.

**SA144J :** Injection cutting wiring with standard connectors (Japan) 4 Cylinder / 3 Cylinder.

**SA144JINV :** Injection cutting wiring with inverted connectors (Japan) 4 Cylinder / 3 Cylinder.

**SA144U:** Universal Injection cutting wiring. This wiring has no connectors and needs to be soldered to the injection wires of the car.

**Standard:** Pin Nr. 1 = Positive – Pin Nr. 2 = Negative (also called “Pulse”)

**Inverted:** Pin Nr. 2 = Positive – Pin Nr. 1 = Negative (also called “Pulse”)

### How to know if a connection is “Standard” or “Inverted”?

To identify which of the two wires is positive, do the following:

- Detach all the connectors from the injectors;
- Set a multimeter to measure DC voltage;
- Connect the negative probe to ground;
- Connect the positive probe to one of the two pins of the injector wiring;
- Turn on the ignition of the car and immediately check the multimeter reading.

If the multimeter reads +12 volts, that pin is the positive.

**WARNING:** the injector +12 volt on some cars might be timed; therefore the reading might disappear a few seconds after the ignition is turned on. Check the polarity of all injector wiring connectors to make sure that they are all polarised in the same way.

**Bosch**



**Japan**



Bosch standaard

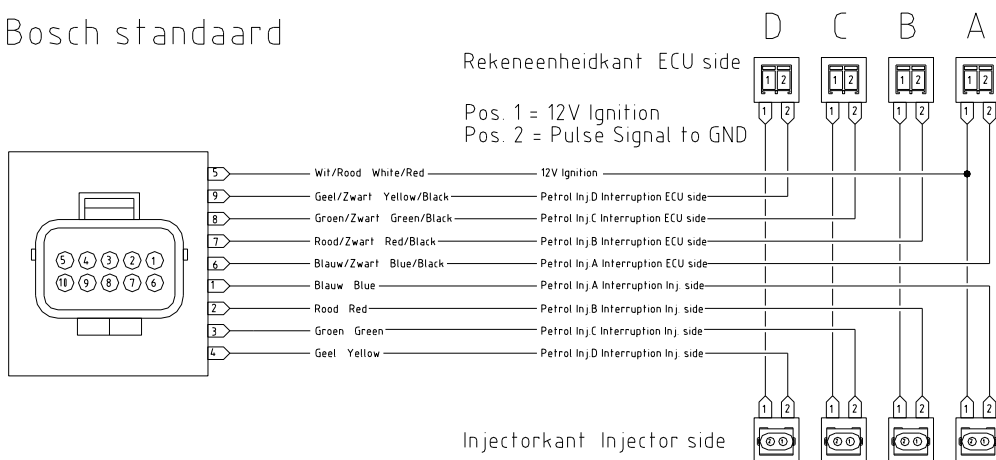

Bosch Inverted

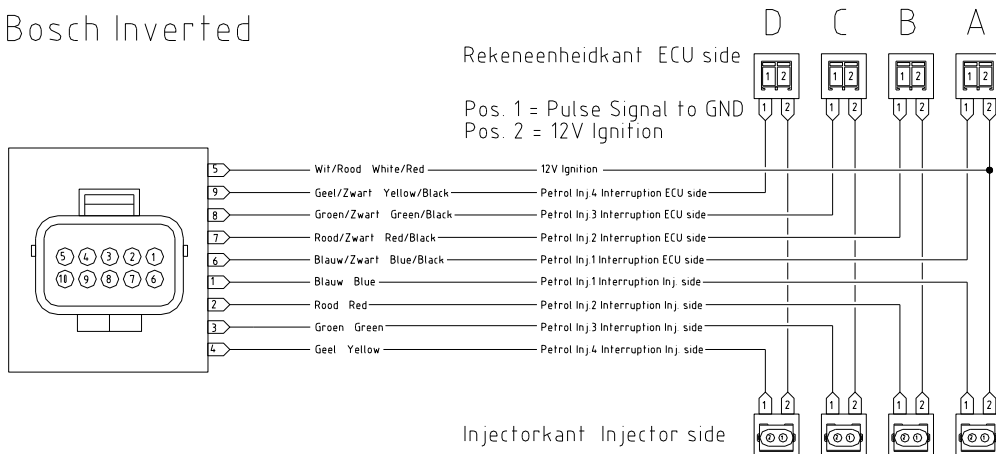

Image is copyright protected by Luccio Engineering



**Universal Injection cutting wiring: SA144U**

All wires of the **SA144U** wiring are free and without connectors. This wiring is used on cars where other types of connectors are used on the injectors or where it is impossible to access the injectors' original connectors. To install this type of wiring, cut the negative wires of the petrol injectors in the order indicated in the figure. The connection direction is very important. The **BLACK striped** wires should be installed towards the petrol ECU and the others toward the injectors. The **WHITE-RED** wire should be connected to any of the injector positives.

**Connection diagram for 4-cylinder cars****WARNING!**

Follow the sequence of connections. The **BLUE** and **BLUE-BLACK** wires must be positioned at the gas injector marked **A**. The others must be connected as indicated in the figure.

**INTERRUPT THE INJECTOR NEGATIVE WIRES.**

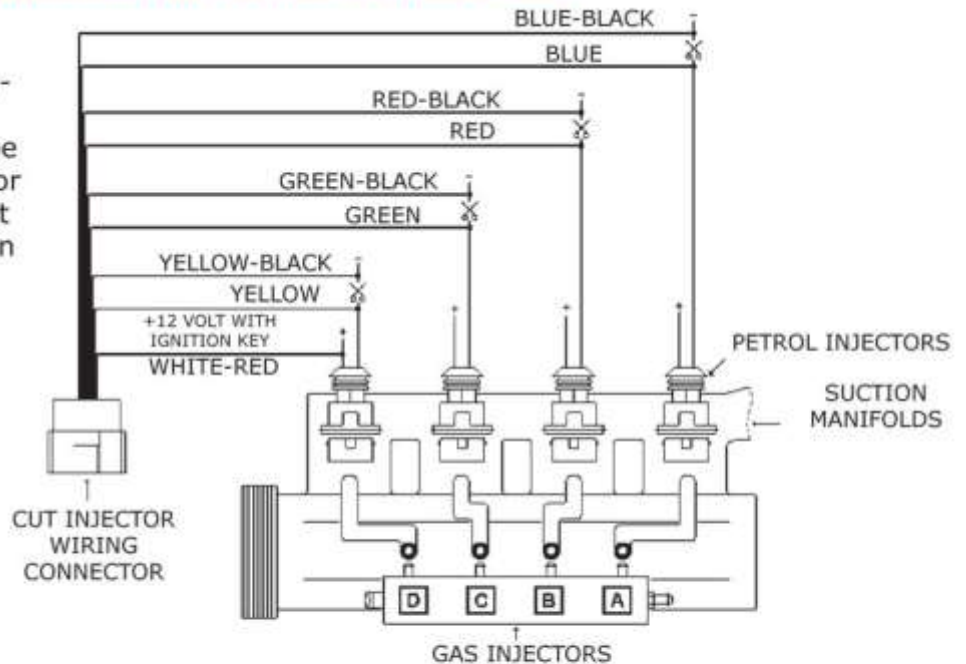
**Connection diagram for 3-cylinder cars****WARNING!**

For a connection on a 3-cylinder car the **YELLOW** and **YELLOW-BLACK** wires should remain disconnected. See the diagram.

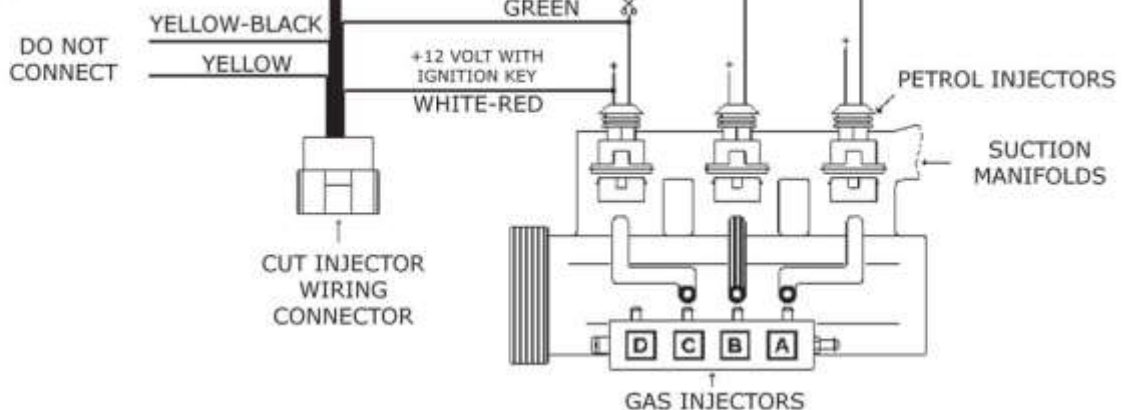



**⚠ N.B.: It is most important to connect petrol injection interruption connectors and gas injector connectors in the same order.**

The connectors for petrol injector interruption of the first cylinder are marked with "A", cylinders 2, 3 and 4 must be deactivated according to the order of the wire harness.

The connector also marked with "A" is used for the gas injector of the same first cylinder. The following gas injectors are connected to connectors B, C and D respectively.

Tip: In the case of an engine with more than 4 cylinders, contemplate the engine as two separate engines, which will make it more easily and orderly working.

5 Cylinder : First 3 cylinder = engine 1 (use first cutting wiring and first gasinjector rail)  
 Last 2 cylinders = engine 2 (use second cutting wiring and second gasinjector rail)

6 Cylinder line : First 3 cylinder = engine 1 (use first cutting wiring and first gasinjector rail)  
 Last 3 cylinders = engine 2 (use second cutting wire and second gasinjector rail)

V6: Bank 1 (Left) = engine 1 (use first cutting wiring and first gasinjector rail)  
 Bank 2 (Right) = engine 2 (use second cutting wiring and second gasinjector rail)

V8: Bank 1 (Left) = engine 1 (use first cutting wiring and first gasinjector rail)  
 Bank 2 (Right) = engine 2 (use second cutting wiring and second gasinjector rail)

**The petrol injection cutting needs to correspond with the gasinjector signals!**

Please consult below given table:

Number of cylinders	Injection cutting		Gasinjector signals	
	Injection-cutting wiring 1 Bank 1	Injection-cutting wiring 2 (Red marker) Bank 2	Gas injector Rail 1 Bank 1	Gas injector Rail 2 (Red marker) Bank 2
3	A (Blue) B (Red) C (Green) -	/	A B C -	/
4	A (Blue) B (Red) C (Green) D (Yellow)	/	A B C D	/
5	A (Blue) B (Red) C (Green) -	A (Blue) B (Red) - -	A B C -	A B - -
6	A (Blue) B (Red) C (Green) -	A (Blue) B (Red) C (Green) -	A B C -	A B C -
8	A (Blue) B (Red) C (Green) D (Yellow)	A (Blue) B (Red) C (Green) D (Yellow)	A B C D	A B C D

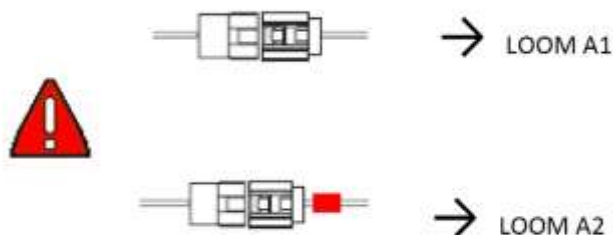

On the next page examples are given of a 6 cylinder engine.



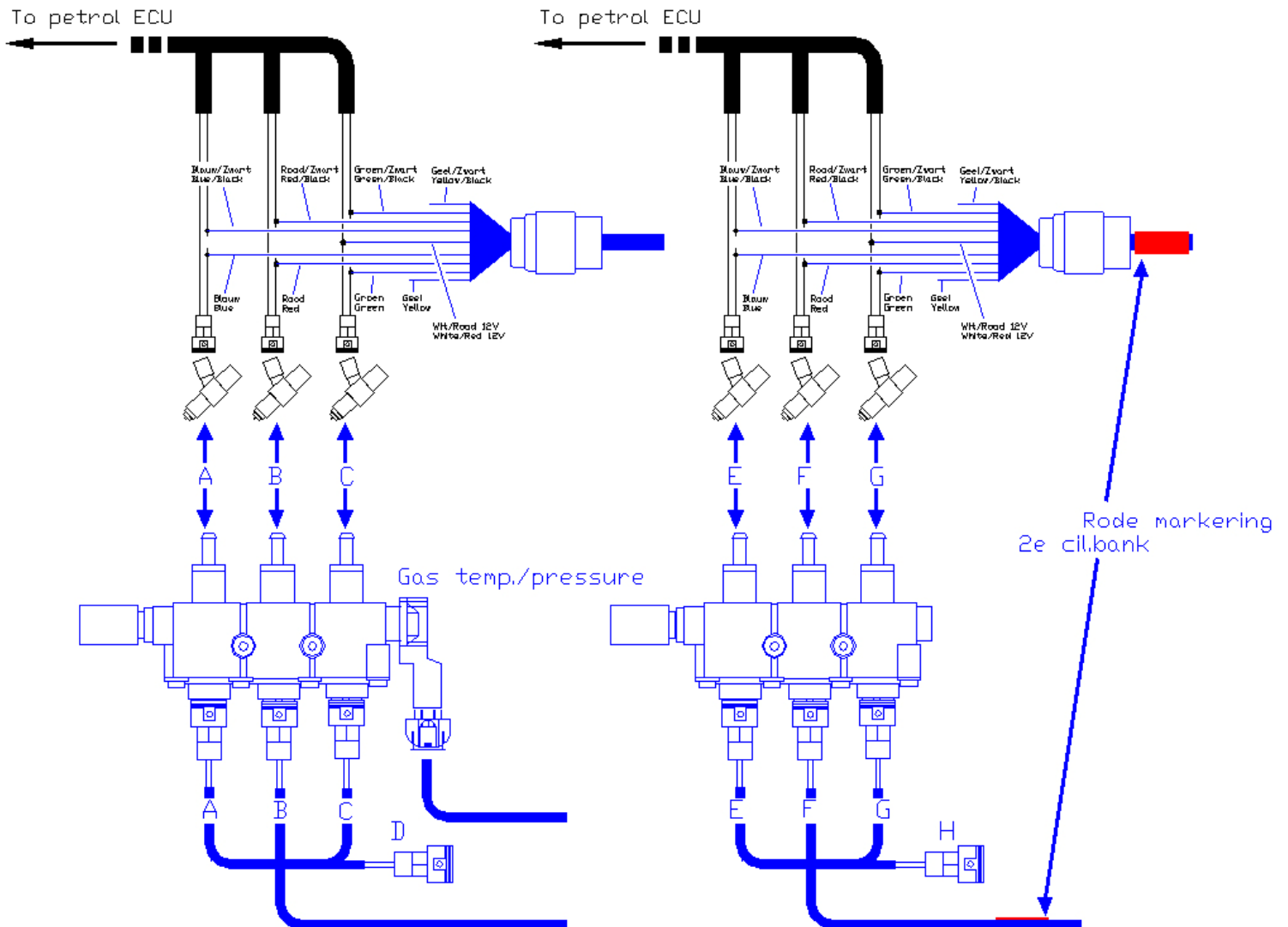
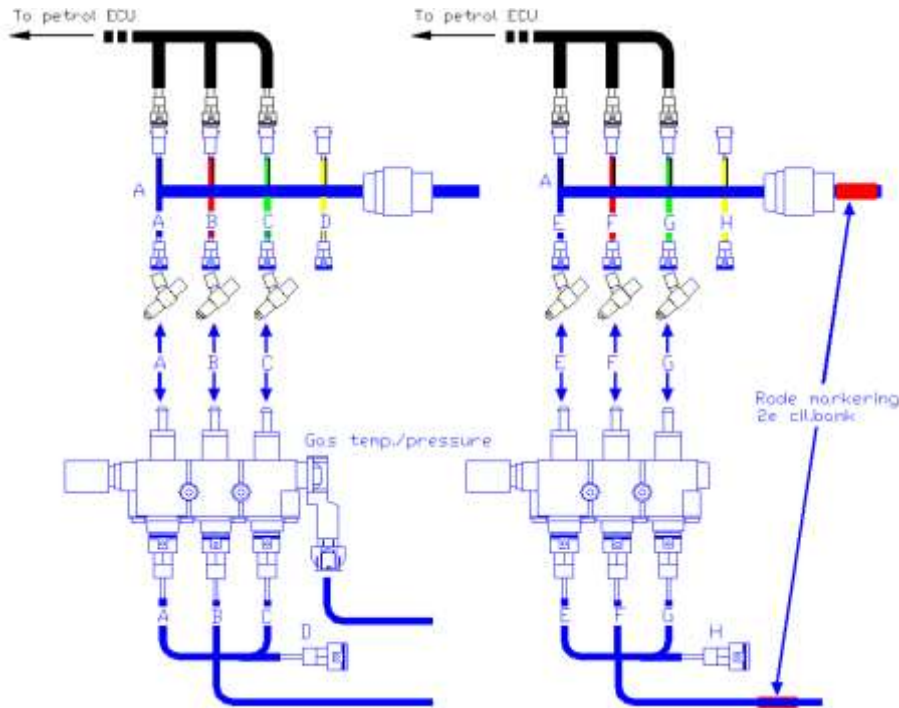



### OBD Connections

Through connection to the vehicle's OBD socket, this new generation of GAS control units makes it possible to acquire information useful for properly setting up the vehicle.

Several carburetion parameters acquired from the PETROL control unit can be seen using the special software for connecting the GAS control unit to the PC, such as:

- Fuel Trims (Fast and Slow)
- Voltage on the rear lambda

Connect a hand-held tester (CODE AEB214), and check the type of connection.

If the tester reads connection types 1,2, or 3, proceed by following the diagram in figure 1.

If the tester reads connection types 6,7,8 or 9, proceed by following the diagram in figure 2.

**ATTENTION: If the tester (CODE AEB214) reads a type of connection that is not stated above, do not connect to any of the signals.**

### OBD Connection 1 for K-line

TYPE OF CONNECTION	CONNECTION DETAILS
Connection type 1	ISO 9141-2
Connection type 2	KWP-2000 Fast Init
Connection type 3	KWP-2000 Slow Init

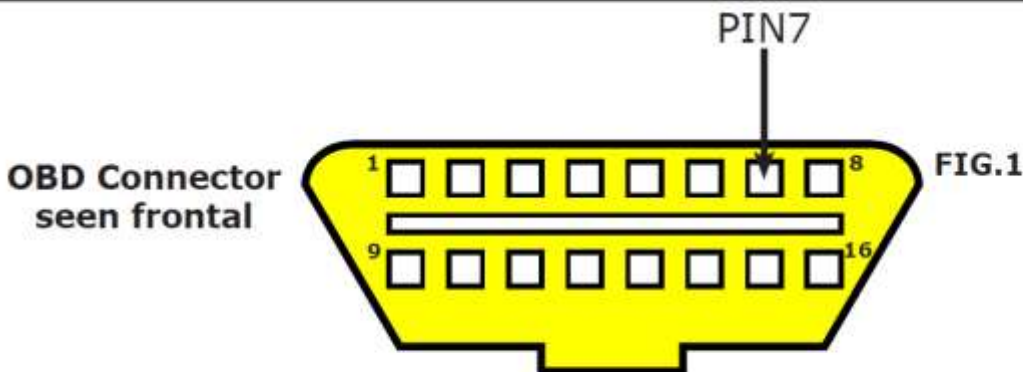

Connect the GREEN wire to the signal found on PIN 7 of the OBD connector.

**ATTENTION: The YELLOW-GREEN and YELLOW-GREY wires must be isolated and not connected.**

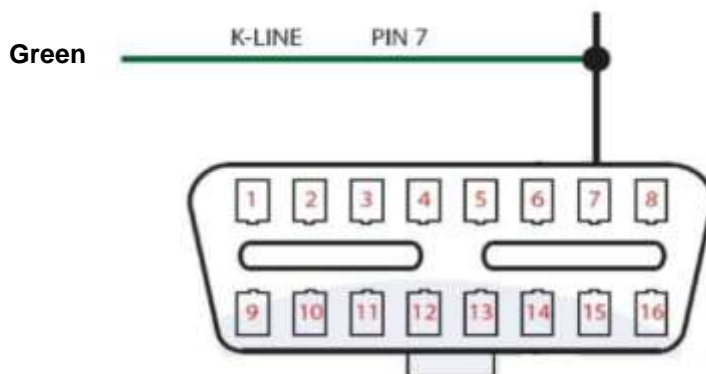



### OBD Connection 2 for CAN BUS

TYPE OF CONNECTION	CONNECTION DETAILS
Connection type 6	CAN Standard 250 Kbps
Connection type 7	CAN Extended 250 Kbps
Connection type 8	CAN Standard 500 Kbps
Connection type 9	CAN Extended 500 Kbps

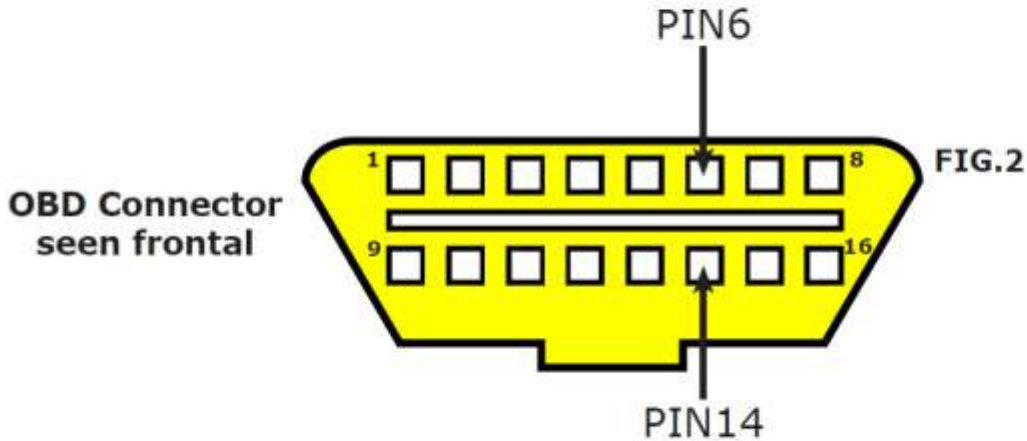

Connect the YELLOW-GREEN wire to the signal found on PIN 6 and the wire YELLOW-GREY to PIN 14 of the OBD connector.

**ATTENTION:** The GREEN wire must be isolated and not connected

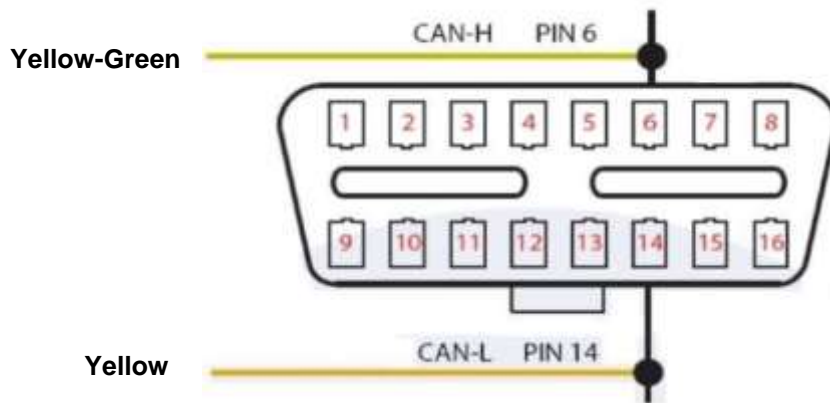



## Userinterface / Gas Switch

The selector switch comprises the following main functions:

- Fuel selection
- LPG level indication
- Acoustic warning signal (buzzer)
- Error code warning LEDs

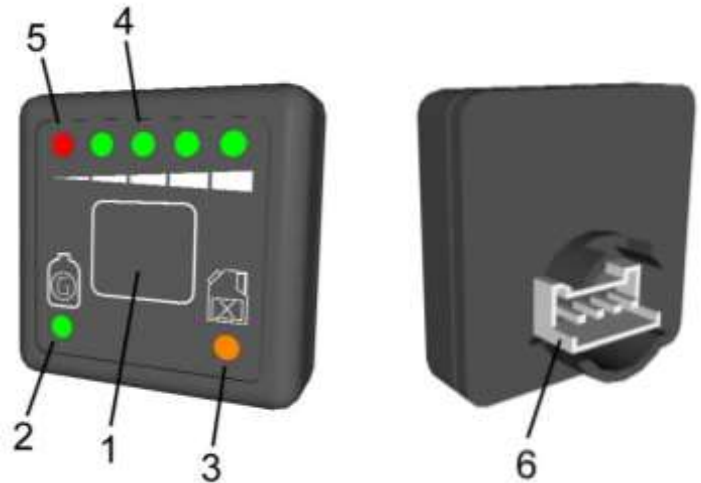

Legend:

1. Gas / Petrol Switch. Press to change
2. Green Gas LED:
  - On constantly: the vehicle is running on gas;
  - Flashes quickly: the system is waiting for the right moment to switch over to gas. N.B.: The vehicle always starts on petrol;
  - Flashes slowly: error code in gas system.
3. Yellow Petrol LED
  - On constantly: the vehicle is running on petrol.
4. LED LPG level indication:
  - Provides an indication of the LPG level in the tank with a resolution of a  $\frac{1}{4}$  tank; 1 green LED =  $\frac{1}{4}$  tank
  - 2 green LEDs =  $\frac{1}{2}$  tank
  - 3 green LEDs =  $\frac{3}{4}$  tank
  - 4 green LEDs = full tank
5. The red LED indicates the reserve tank function.

The fuel selector switch is connected to the wire harness via a 4-pin connector located at the rear of the switch. The switch and the ECU use serial communication for exchanging information about the fuel selection, fuel level, tank level and possible error codes in the system.

### **Emergency start procedure on gas**

If the petrol system no longer works, due to an empty petrol tank, for example, the vehicle can be started directly on LPG.

Emergency start procedure switch type B:

- Switch on the ignition without starting the engine (the LEDs on the switch will illuminate);
- Keep the switch pressed for over 5 seconds (the green LED on the switch will now illuminate constantly);
- Now start the engine, which will start directly on LPG. (If the engine is cold, this may prove difficult due to the lack of heat energy for the gas that has to be evaporated.)

### **Installation of the Switch**

The Position of the connector on the back of the switch is excentric. Take this in account when drilling the hole.

Mount the switch on the dashboard in such a way that the driver always can see the fuel gauge without leaving sight from the road.

Remove the protection of the double sided tape on the switch and mount the switch on the chosen location.

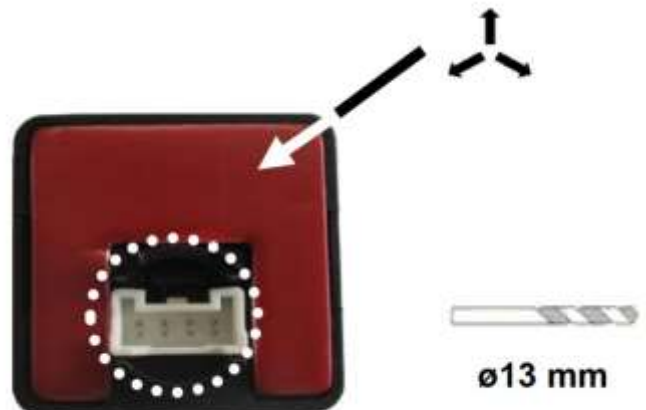



## **Maintenance and service**

### **Introduction**

The VGI system has been designed in such a way that minimal maintenance and service is required. The state of the system still depends on the quality of the installation and prior maintenance work.

Maintenance must be carried out at regular intervals, as referred to in the maintenance plan in the user manual for the system.

The first maintenance inspection is scheduled for 20,000 km after installation of the system, with an interval of 30,000 km thereafter.

After the maintenance inspection, the maintenance plan in the user manual must be filled in. The following components must be listed.

- Date of maintenance inspection
- Vehicle mileage
- Tick activities that have been performed; filter replacement and general check.
- Initials of the executing party and the stamp of the dealer or installer.

A knowledge of the content of this entire installation manual, the correct equipment and the interface software is required in order to carry out maintenance work.

The following sections of this chapter will list and describe all components that must be implemented during maintenance and servicing activities. Ensure this is done thoroughly and carefully and preferably in the same order for the sake of customer satisfaction.

### **Maintenance**

#### **Error codes and diagnostic check**

Connect your PC or laptop along with the interface software to the gas ECU using the interface cable. Please refer to the Software Manual for connection-related information and how to use the interface software.

Check whether error codes are present in the system. (Even if the system has not been changed back to petrol and the selector switch does not provide a warning, an error code may be present nevertheless. (This depends on the type of error code.)

Resolve the problem that causes this error code. Consult the fault table to this end.

After the cause has been resolved, delete the error code from the memory of the gas system ECU and check whether the error code reappears. If this is indeed the case, the problem has not been resolved properly or the cause must be sought elsewhere.

#### **External check**

Carry out a visual inspection on the entire system and look for any damage to and wear and tear on all components. Pay particular attention to the following aspects:

- Leaks in and damage to the filling hose and connectors.
- Leaks in the appendages of the tank.
- Leaks in and damage to gas feed hose and connectors.
- Condition of electrical connections on the tank.
- The attachment of the tank.
- The attachments of various components below the bonnet.
- Leaks, damage and wear and tear with regard to dry gas hoses and connections.
- Leaks, damage and wear and tear with regard to water hoses and connections.
- Electrical connections of the wire harness below the bonnet.

Deal with any leaks or damages and ensure the problem does not occur again by routing hoses and pipes differently in order to avoid wear and tear or by adding additional protection.

#### **Filter unit maintenance**

The filter element must be changed on a regular basis. The element must be replaced for the first time 20,000 km after the installation of the LPG system and at an interval of 30,000 km thereafter. Use the filter replacement set.

#### **System pressure check and adjustment**

Check and adjust the system operating pressure after the filter element has been replaced. An obstructed filter element will cause a decrease in pressure. In this case, the pressure regulator will provide the correct pressure, but the pressure behind the filter will be lower.





Check the system operating pressure while the engine is idling on gas and use the interface software for this purpose. The system operating pressure must be between 0.95 and 1.20 bar.

## RECOMMENDATIONS

To get the best from LPG, the engine of your vehicle has to be correctly tuned up and it has to be maintained (for mechanical and electrical requirements).

In addition to the O.E.M. maintenance for the vehicle, it is recommended to: **Every 20.000 km:** the substitution of the spark plugs, the check of the exhaust gas with analyzer, the check / substitution of the air filter, the check / substitution of the gas filter, the check of the good functioning of the lambda sensor. **Every 30.000 km:** check of valves slack (valves play).

We recommend to check the good functioning of the petrol injection system every 4.000 / 5.000 km, driving for some kilometres on petrol. It is important to keep the petrol level not under 1/4 of the tank capacity to not damage the good functioning of the petrol pump. LPG has a particular smell so that it is simple to identify leaks; in case of gas leaks it is necessary to switch off the engine, switch off the light dashboard, change over petrol the switch/indicator, do not smoke, verify that there are no ignition source near the vehicle. When the LPG smell disappears, isolate the tank. Now it is possible to use the vehicle running on petrol and we suggest to you to check the system to an installer. In case of the smell of LPG does not disappears, switch off the engine, isolate the tank, do not switch the engine no more before the verify of your installer.

Remember these simple cautions: switch on the hand brake, switch off the engine, switch off the lights dashboard, do not smoke.

FOR SAFETY REASONS, TANK HAS NOT TO BE FILLED FOR OVER THAN 80% OF ITS CAPACITY (I.E. WITH A TANK OF 80 LT., IT IS POSSIBLE TO STORE ABOUT 64 LT).

The limit of the filling it is ensured from the valve placed on the LPG tank. In case of a filling over the 80% , we recommend to not leave the vehicle parked at the sun for many hours, before you don't finish the fuel in excess. LPG tank has a lifetime of 10 years (European regulation). Tank manufacturing date it is normally placed near the valves.

## IN CASE OF ACCIDENT

The main cautions are equal to the ones for a petrol powered vehicle, remember always to switch on the hand brake, switch off the engine, (automatically it will be activated a safety device that stops the flow of the gas to the engine), switch off the lights dashboard.